



Time Tested • Time Proven



Installation Instructions

All specifications are subject to change without notice.

ROADMASTER, Inc. 6110 N.E. 127th Ave. Vancouver, WA 98682 800-669-9690 Fax 360-735-9300 www.roadmasterinc.com

Note: all RoadWing products are for 2-inch hitch receivers only.

1. Remove the rubber flaps from the package, to allow them to uncoil. (The flaps will uncoil more readily at a warm temperature.)
2. Install the RoadWing yoke – without the flaps – on the vehicle by sliding the hitch ball mount (Figure 1) through the RoadWing (Figure 1) and mounting it into the hitch receiver (Figure 1).

Note: due to the powder coat finish, the RoadWing or ball mount may require lubrication for the RoadWing to slide on and off the first few times.

Note: the ball mount shank must extend a minimum of two inches past the hitch receiver. If the shank does not extend at least two inches past the hitch receiver, replace the hitch ball mount.



WARNING

Do not modify the ball mount or shank to accommodate the RoadWing. Modifying the hitch ball mount may cause it to fail during towing, which may cause property damage, personal injury or even death.

3. With the RoadWing installed on the ball mount and both set bolts (Figure 1) tightened, and the vehicle parked on level ground so that the RoadWing is level, measure from the bottom of the square tubing (Figure 2) to determine the flap length.

Note: ROADMASTER recommends either attaching the trailer to the vehicle or subtracting two to three inches to allow for the towed weight.

4. Cut the flaps – after determining the correct length, measure from the top of the flap down to the desired length. Mark the smooth side, then carefully cut the flap with a straight edge and razor knife (Figure 3).

5. Attach the flaps as shown in Figure 4. Tighten the Nyloc nuts until they look and feel snug (do not overtighten).

IMPORTANT

RoadWing is designed to help reduce the damage to the trailer and its contents while being towed. Although RoadWing will significantly reduce the amount of damage, RoadWing will not eliminate all damage. Correspondingly, ROADMASTER expressly disallows any and all claims related to rock chips, dings, scratches or any other damage incurred to the trailer and its contents.



WARNING

Failure to follow these instructions may cause property damage, personal injury or even death.

CAUTION

The RoadWing flaps can be warped or otherwise damaged by the heat from exhausts at the rear of the vehicle. If an exhaust is close to one of the flaps, install a 'turn down' extension on the engine exhaust to redirect the exhaust away from the flap. Otherwise, non-warranty damage to the flap may occur.

Figure 1

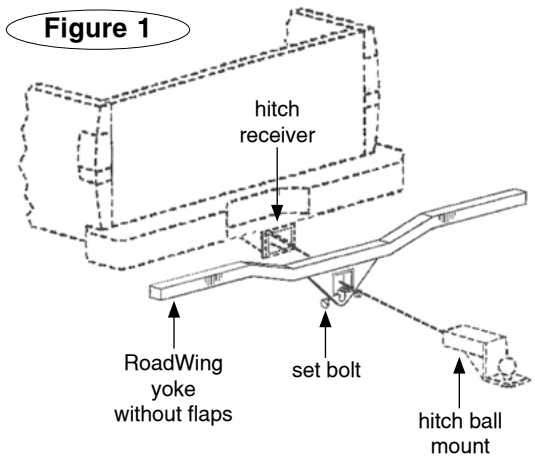

Figure 2

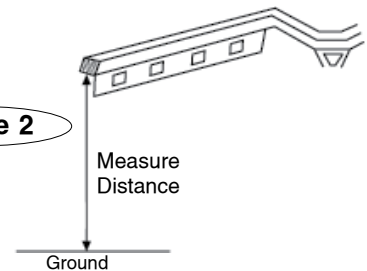

Figure 3

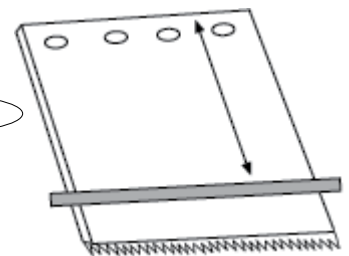

Figure 4

