



Installation Instructions

Thank you for purchasing our sway bar kit. Please read through these instructions before installation.

Auxiliary Rear Anti-Sway Bar Kit for the Ford F53

part #1139-143

1½" diameter

Note: If the factory U-bolts are not long enough to install this kit, you will need to order new ones. For square-top U-bolts, order kit #590050-00; for round top U-bolts, order kit #590050-10.



INTRODUCTION

Thank you for purchasing this anti-sway bar kit. This kit is designed to improve the handling characteristics of your Ford F53 by reducing the body roll and balancing the weight transfer during cornering. The anti-sway bar kit is engineered for long life and trouble-free performance. All the hardware needed for installation is included in this kit. Refer to the PARTS LIST in these instructions to identify the parts.

SUGGESTED TOOLS

The following tools are suggested to complete the installation procedures:

- General hand tools
- 1/4", 1/2" sharp drill bits
- 5/8", 11/16", 3/4", 15/16", 1-1/8" sockets
- Torque wrench

WARNING

Failure to follow these instructions can result in property damage, personal injury or even death.

- If raising the vehicle to install the anti-sway bar, always support the vehicle with jack stands at both frame rails or at the rear axle before working underneath. Ensure that the jack stands are securely positioned, and are rated at or above the weight of the vehicle.
- The installer must read the instructions and use all bolts and parts supplied. Use only the parts supplied by ROADMASTER to install this kit.
- Minor modifications are sometimes necessary due to slight vehicle variations, even for the same year, make and model.
- Regardless of year, make and model, a wide range of options for specific applications may or may not interfere with the installation. It is the installer's responsibility to make certain that equipment is not damaged once the suspension solution travels through the full range of motion. Failure to ensure adequate clearance could result in non-warranty property damage, personal injury or even death.
- If running changes were made by the manufacturer after this kit was designed, there may be weldments, braces, gussets, or other structural items which interfere with the installation. It is the installer's responsibility to allow for these running changes without sacrificing the structural integrity of the anti-sway bar. Failure to securely fasten the anti-sway bar could result in property damage, personal injury or even death.
- ROADMASTER will not be responsible for any damage or injury resulting from any modification or alteration.
- Check ALL the fasteners for tightness before and after road testing the vehicle.
- Do not use this document for custom fabrication, as it may not show all parts or structural components.
- Do not use an air impact wrench when re-installing bolts, as stripped threads may result.
- This anti-sway bar is only warranted for the original installation. Installing a used anti-sway bar on another vehicle is not recommended and will void the warranty.

PARTS LIST

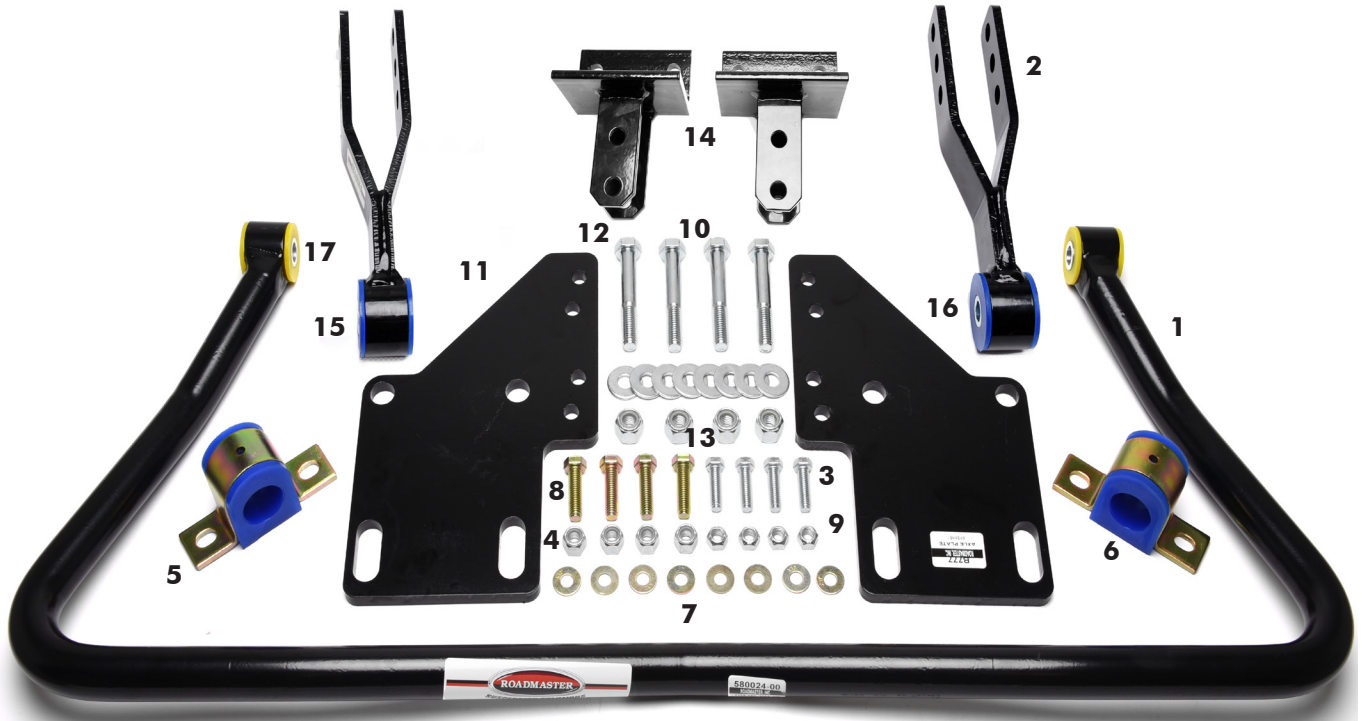

Part #1139-143

Part #	Description	Qty	Part #	Description	Qty
1.	580024-00 Anti-sway bar, 1-1/2"	1	10.	350308-00 Washer, 1/2"	8
2.	B1003 Shackle	2	11.	B777 Bracket, flat	2
3.	350703-00 Bolt, 1/2" x 2"	4	12.	350158-00 Bolt, 5/8" x 4"	4
4.	350259-00 1/2" NC Locknut	4	13.	350263-00 Nut, 5/8"	4
5.	B141 Bracket, U-clamp	2	14.	B734 Frame brackets	2
6.	205217-10 Bushing, split poly	2	15.	205202-10 Shackle Bushing	4
7.	350308-80 Washer, 1/2"	8	16.	205503-00 Sleeve	4
8.	350096-80 Bolt, 1/2" x 1-3/4"	4	17.	205209-00 Bushing	4
9.	350259-00 Locknut, 1/2"	4	18.	*400011-30 Aqualube Grease	1

*not pictured

INSTALLATION

The following instructions must be followed in the order listed to ensure a proper installation and to preserve the **ROADMASTER** warranty.

1. Remove the parts from the box and match it with the parts list.
Make sure that the kit has all the parts shown on the parts list on page 2.
2. Apply parking brake.
The following procedures can be done with the wheels of the vehicle on the ground.

Locate u-bolts holding springs to axle.
3. *Note:* do not remove the factory anti-sway bar. This kit is designed to support the factory anti-sway bar — not replace it. Remove nuts from u-bolts on one side. Retain the factory axle bracket and add a flat plate (B777) with small holes positioned toward front and center of vehicle. Secure with the factory nuts and washers. Torque to the manufacturer's specifications. Repeat the process on the opposite side (Figure 1).
4. Install the saddle brackets and bushings on the anti-sway bar.
Lubricate the inside of the split bushings with the provided lubricant (Figure 2). Install the bushings on the anti-sway bar near the arms. Slide the saddle brackets over the split bushings.
5. Install the anti-sway bar assembly to the flat plates.
Lift the anti-sway bar assembly into position so that the saddle bracket holes align with the flat plate holes. Use the provided bolts (350703-00), washers (350308-80) and nuts (350259-00) to attach it. Tighten to 35-45 ft.-lbs. *Note:* for applications under 18,000lb GVWR, use the holes offset to the center of the plate. For applications over 18,000lb GVWR or with bottom-mounted OE sway bar, use the holes closest to the edge of the plate (Figure 3).
6. Locate shackles and fasteners.
Attach shackle (B1003) to the anti-sway bar end with the provided bolts (350158-00) and nuts (350263-00). Do not tighten yet. Using the provided bolts (350158-00) and nuts (350263-00), attach the hanger bracket to the top of the shackle.

Note: There are three different sets of holes in the shackle that can be used for mounting the anti-sway bar to the endlinks. Use the hole configuration that allows the anti-sway bar to ride as level as possible. Figure 4 (next page) depicts the optimal angle for the installation. There are also two holes in the frame bracket hanger that can be used for additional adjustments, as needed, to achieve the optimal angle.

Figure 1



Figure 2

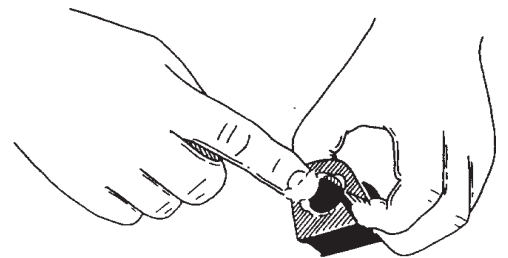
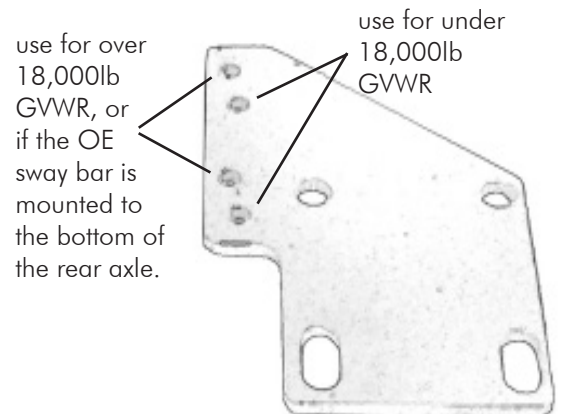

Figure 3



INSTALLATION

7. Locate and drill the shackle bracket mounting points.

Rotate the sway bar up and hold the shackle bracket against the bottom of the frame rail. Locate the shackle bracket so that the shackle is vertical with the vehicle at normal ride height. Use a clamp or locking pliers to hold the bracket in place. Check the inside of the frame rail for wiring, brake lines or other obstructions and relocate before drilling. Using the pre-existing holes in the shackle bracket as a template, drill two 1/2" holes through the frame rail of the vehicle. Bolt the shackle brackets to the frame rail using the provided 1/2" bolts, washers and nuts. Use washers on both the outside of the shackle bracket and the inside of the frame rail. Torque to 57 lb-ft.

8. Finally, tighten the shackles.

Tighten the 5/8" upper and lower shackle bolts to 30-45 lb-ft. Recheck all other fasteners for proper torque (Figure 4). Note: Due to manufacturing variances, your shackle may look slightly different than the one shown in Figure 4.

9. Test drive and re-inspect installation.

Listen for any unusual noises.

Figure 4

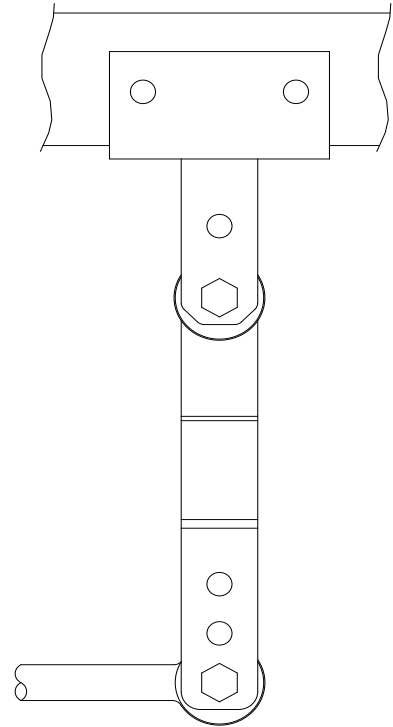

WARNING

Over-tightening the grommets may cause premature failure of the grommets and /or the end links. If the grommets fail, the anti-sway bar will not stabilize the vehicle at full capacity, which may cause reduced cornering ability or other reductions in vehicle handling or performance.

Failure to follow these instructions may cause property damage, personal injury or even death.

WARNING

After road testing, re-check all fasteners for proper tightness — if a fastener has worked loose or fallen off, re-tighten or replace it.

Without all kit components properly tightened or in place, the anti-sway bar will not stabilize the vehicle at full capacity, which may cause reduced cornering ability or other reductions in vehicle handling or performance.

Failure to follow these instructions may result in property damage, personal injury or even death.

WARNING

The anti-sway bar is not a load-bearing component

Do not tow or hoist the vehicle using the anti-sway bar or its mounting brackets as attachment points. The anti-sway bar is not designed to carry the weight of the vehicle and may collapse, which will damage the anti-sway bar components, the suspension, or other components. The vehicle will detach or fall, which may cause severe personal injury.

Failure to follow these instructions may result in property damage, personal injury or even death.

BOLT TORQUE REQUIREMENTS

STANDARD BOLTS			U-BOLTS	
Thread	Grade	Torque	Thread	Torque
3/8.....	5.....	30 lb-ft	3/8-24	35 lb-ft
7/16.....	5.....	50 lb-ft	1/2-20	70 lb-ft
1/2.....	5.....	75 lb-ft	5/8-18	140 lb-ft
5/8.....	5.....	140 lb-ft	3/4-16	250 lb-ft
			7/8-14	400 lb-ft

Note: Endlink bolts use grommets and should NOT be torqued. Tighten these bolts by hand until the grommet starts to deform. Also, these torque values are intended as general guidelines. Roadmaster does not warrant this information to be accurate for all applications and disclaims all liability for any claims or damages which may result from its use.