



# BASEPLATE KIT INSTALLATION INSTRUCTIONS

**KIT# 1187-1A**

08/02/16  
KS

ROADMASTER, Inc. 6110 NE 127th Ave. Vancouver, WA 98682 360-896-0407 fax 360-735-9300 www.roadmasterinc.com

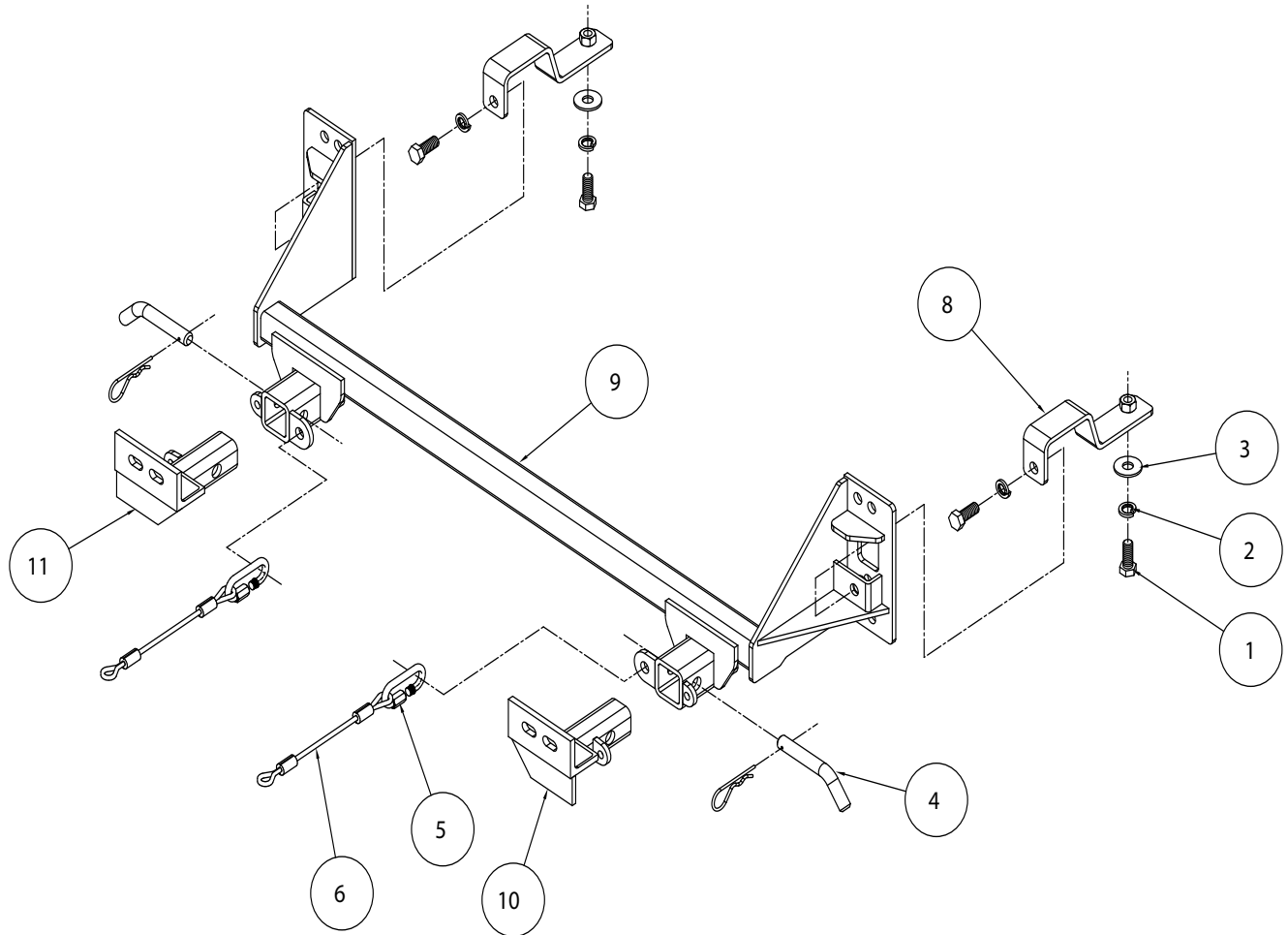

ITEM	QTY	NAME	MATERIAL
1	4	1/2" x 1 1/4" BOLT	350094-00
2	4	1/2" LOCK WASHER	350309-00
3	2	1/2" FLAT WASHER	350308-20
4	2	DRAW PIN W/ CLIP	357035-00
5	2	QUICK LINK	200008-00
6	2	8" SAFETY CABLES	500646-08
7	2	ZIP TIES	300140-8
8	2	REAR MOUNTING PLATE	C-001535
9	1	MAIN RECEIVER	C-001537
10	1	DRIVER SIDE ARM	C-002282
11	1	PASSENGER SIDE ARM	C-002283



# BASEPLATE KIT INSTALLATION INSTRUCTIONS

**KIT# 1187-1A**

08/02/16  
KS

ROADMASTER, Inc. 6110 NE 127th Ave. Vancouver, WA 98682 360-896-0407 fax 360-735-9300 www.roadmasterinc.com

This is one of our XL series brackets, which allows the visible front portion of the bracket to be easily removed from the front of the vehicle (Fig.A and Fig.B). The bracket kit consists of a main receiver brace, two rear braces, two removable front bracket arms and a hardware pack. The main receiver brace and rear braces mount to the frame rails and the removable front brackets install in the main receiver braces.

Before starting the installation, lay out the kit components in order, as they will be used. This will give you a visual idea of how the components work, and will also confirm that everything is present and accounted for.



**IMPORTANT:** All baseplates **must** be assembled with all the bolts left loose for final adjustment and positioning (before tightening) unless otherwise instructed. All bolts **must** be torqued for proper strength. If more than one bolt is used per fastening point, the diagram may only show one. Use flat washers over all slotted holes and lock washers on all fasteners.

## WARNING

Failure to heed these warnings or follow the installation instructions may result in a voided warranty, loss of towed vehicle, personal injury or death.

- Do not weld or modify this baseplate or its components. Welding or modification will void the warranty.
- Do not use this document as a basis to design/fabricate a baseplate, as it may not show all parts or structural components.
- We strongly recommend professional installation.
- If the towed vehicle has been in an accident, it must be properly repaired before attaching the baseplate. Do not install the baseplate if any structural frame damage is found.
- The installer must use all bolts and parts supplied. If running changes were made by the vehicle manufacturer after this kit was designed, some bolts or other fasteners may no longer be the correct size. It is the installer's responsibility to verify this kit is securely fastened to the vehicle.
- Use Loctite® Red on all bolts used to secure this baseplate. Torque all bolts to the specifications found at the end of these instructions. Do not over-torque the bolts or failure may occur.
- The installer must inspect the baseplate to ensure adequate clearance, particularly around hoses, air conditioner lines, radiators, etc. or non-warranty failure may result.
- Roadmaster manufactures many styles of baseplates. If your baseplate has removable arms, they must be removed before driving the vehicle, unless the arms can be pinned or padlocked in place. If not secured, the arms could vibrate out.
- Some motorhome chassis have such a tight turning radius that you can damage your motorhome, towed vehicle, tow bar or baseplate while turning sharply. Before getting on the road, test your turning radius in an empty parking lot. Turning too sharply could result in non-warranty damage to your towing system, motorhome and/or towed vehicle.
- Do not back up with the towed vehicle attached or non-warranty damage will occur to your towing system or vehicles.
- The safety cables must connect the towing vehicle to the towed vehicle frame to frame, with the cables crossed, with enough slack for sharp turns. See cable instructions for proper routing. Failure to do so will result in non-warranty damage and/or the loss of the towed vehicle.
- This kit is designed for use with ROADMASTER tow bars and ROADMASTER adapters only. Using this kit with other brands, without an approved ROADMASTER adapter, may result in non-warranty damage or injury.
- Receiver extensions and out-of-level towing situations of 3 inches or more. This can cause the system to swing much higher and lower, causing excessive strain on the tow bar, baseplate and frame. That can cause the towing system to fail, causing property damage, personal injury or even death. If you must use a receiver extension or drop hitch to tow, it will reduce your receiver's weight capacity by 1/3 to avoid damaging your system. Never use more than one extension and/or drop hitch, as this will void your warranty.
- Every 3,000 miles, the owner must inspect all mounting points for cracks or fatigue, and check the fasteners for proper torque, according to the bolt torque requirements chart on the last page of these instructions.
- The owner must follow the vehicle manufacturer's instructions to prepare the vehicle for towing. Failure to do so may cause severe damage to the vehicle.
- This baseplate is only warranted for the original installation. Installing a used baseplate on another vehicle is not recommended and will void the warranty.





# BASEPLATE KIT INSTALLATION INSTRUCTIONS

**KIT# 1187-1A**

08/02/16  
KS

ROADMASTER, Inc. 6110 NE 127th Ave. Vancouver, WA 98682 360-896-0407 fax 360-735-9300 www.roadmasterinc.com

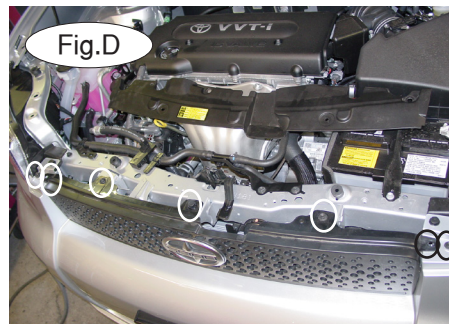

1. **Important:** please use all supplied bolts and parts and read all instructions carefully before beginning this installation. The majority of questions you may have can be answered within the text, and proper installation will ensure safe and secure travel. Now, begin the installation. Start by removing seven plastic fasteners attaching the radiator cover to the grille and core support (Fig.C). Remove the radiator cover. Next, remove four 10mm (head) bolts and three plastic fasteners attaching the grille and the fascia to the core support (Fig.D). **For Scion tC models:** proceed to step 2.



2. **For Scion tC models only:** remove nine plastic fasteners and two plastic fasteners with bump stops attaching the radiator cover and fascia to the core support (Fig.E). **For all other models:** proceed to step 3.

3. Remove one 10mm (head) bolt and one plastic fastener attaching the outer edge of the fascia to the fender liner (Fig.F).

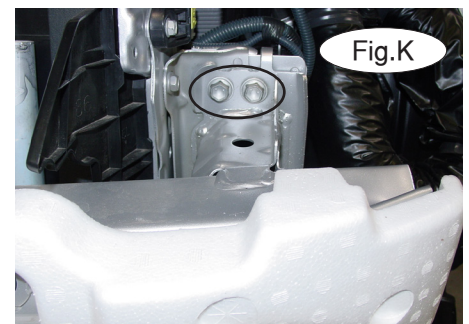
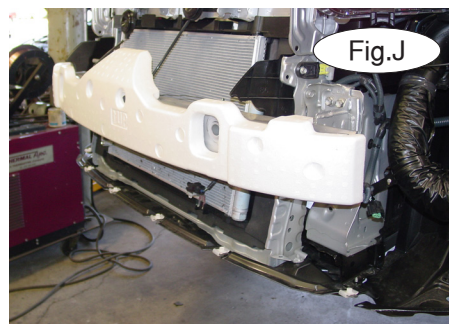
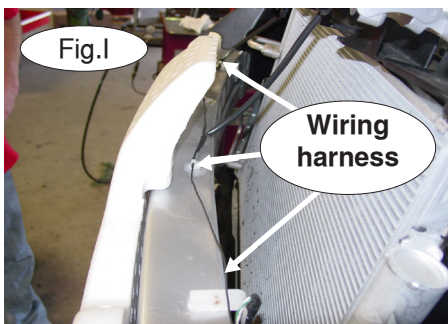

4. Remove eight 10mm (head) screws attaching the bottom of the fascia to the splash shield (Fig.G).

5. Now, pull out and forward on both corners of the fascia to remove it (Fig.H).

6. Remove the five plastic fasteners holding the wiring harness to the bumper core (Fig.I), and remove the wiring harness.

7. Remove four 14mm (head) bolts from each side of the bumper core to remove the bumper core and the foam shock absorption insert (Fig.J). There are two bolts on the top (Fig.K) and two bolts on the bottom (Fig.L). *Note:* the bumper core and foam shock absorption pad will not be replaced. Retain both and their respective attachment hardware in case the bracket is ever removed.

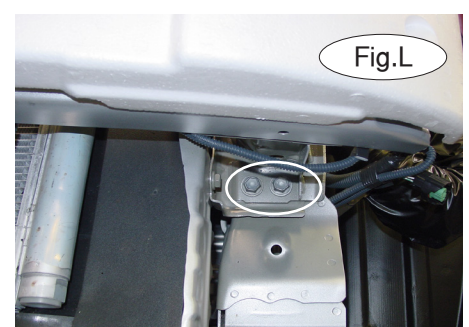





# BASEPLATE KIT INSTALLATION INSTRUCTIONS

**KIT# 1187-1A**

08/02/16  
KS

ROADMASTER, Inc. 6110 NE 127th Ave. Vancouver, WA 98682 360-896-0407 fax 360-735-9300 www.roadmasterinc.com

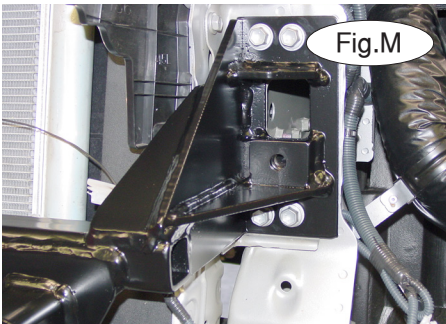

Fig.M

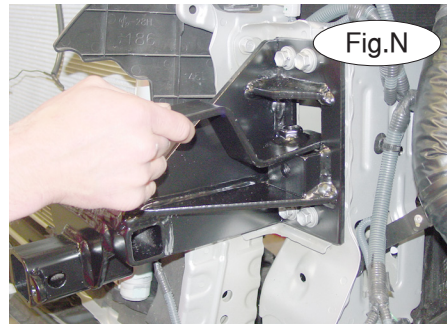

Fig.N

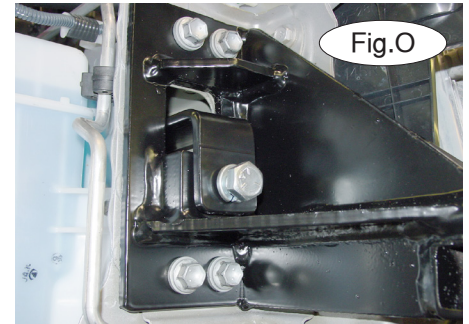

Fig.O

8. Now, set the main receiver brace over the ends of the frame rails and bolt into place using the eight bolts you removed in step 7 (Fig.M). Tighten to the torque specifications for a 10mm x 1.25 bolt listed at the end of these instructions.

9. Insert the rear brace through the opening in the frame rail (Fig.N). Then, bolt to the main receiver brace using a 1/2" x 1 1/4" bolt and lock washer (Fig.O). *Note:* the opening in the frame rail may need to be enlarged slightly with a die grinder. Repeat for the other side.

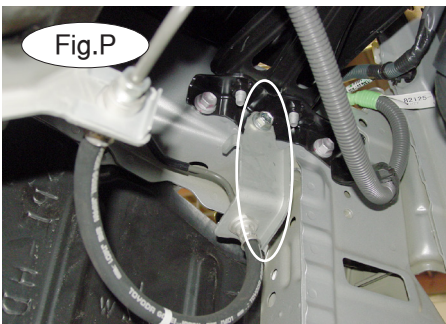

Fig.P

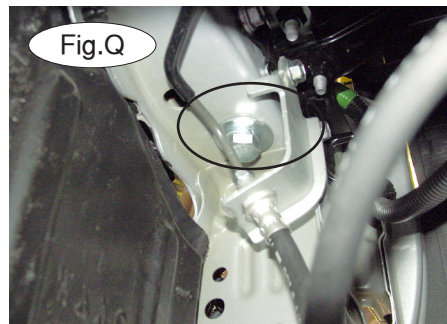

Fig.Q

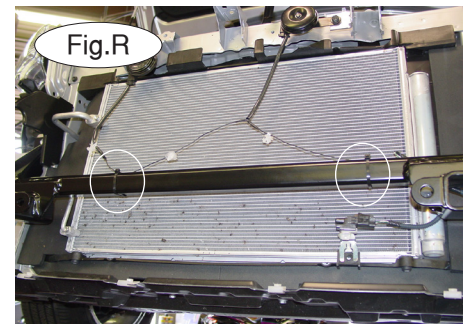

Fig.R

10. Temporarily remove the 12mm (head) bolt and mounting bracket for the clutch slave cylinder line (Fig.P).

11. Make sure the rear mounting hole in the rear brace aligns with the existing hole in the bottom of the frame. Bolt through the frame rail and into the rear brace using the supplied 1/2" x 1 1/4" bolt, flat washer and lock washer (Fig.Q). Repeat for the other side.

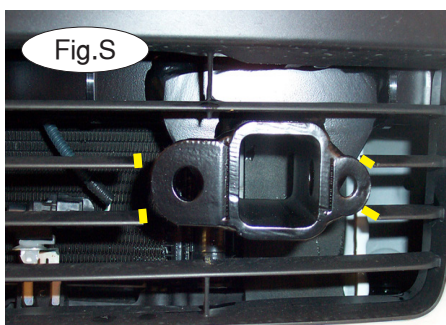

Fig.S

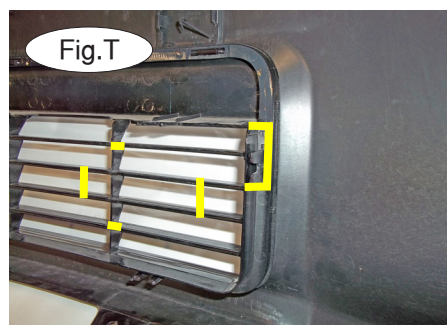

Fig.T

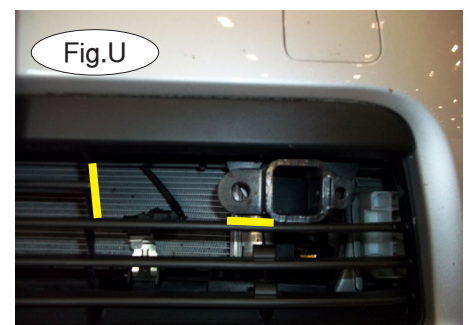

Fig.U

12. Tighten all remaining bolts to the torque specifications listed at the end of these instructions.

13. Now, bolt the clutch slave cylinder line bracket back into place.

14. Using the supplied zip ties, secure the wiring harness you removed in step 6 to the main receiver brace (Fig.R).

15. Replace the radiator cover and fascia by reversing steps 1 through 5.

16. Trim the fascia to allow clearance for the main receiver brace. **For '11 to '12 Scion xB models:** use the yellow lines in Figure S as a guide for trimming. **For '13 Scion xB models:** use the yellow lines in Figure T as a guide for trimming. **For Scion tC models:** use the yellow lines in Figure U as a guide for trimming. **For all others:** use Figure V as a guide for trimming.



Fig.V



# BASEPLATE KIT INSTALLATION INSTRUCTIONS

**KIT# 1187-1A**

08/02/16  
KS

ROADMASTER, Inc. 6110 NE 127th Ave. Vancouver, WA 98682 360-896-0407 fax 360-735-9300 www.roadmasterinc.com

17. Insert the removable front bracket arms into the front receiver braces, and secure them in place with the supplied 5/8" draw pins and spring pins.
18. Attach the 8" safety cables with the cable connectors (Q-Links) to the front of the receiver braces (Fig.W).
19. Attach the ends of the safety cables to the tow vehicle's safety cables and tow bar.
20. Install the tow bar to the mounting bracket according to the manufacturer's instructions.



## BOLT TORQUE REQUIREMENTS

Note: The torque values represented below are intended as general guidelines. Torque requirements for specific applications may vary. Roadmaster does not warrant this information to be accurate for all applications and disclaims all liability for any claims or damages which may result from its use.

### STANDARD BOLTS

Thread Size	Grade	Torque
5/16.....	5.....	13 ft./lb.
3/8.....	5.....	23 ft./lb.
7/16.....	5.....	37 ft./lb.
1/2.....	5.....	56 ft./lb.
5/8.....	5.....	150 ft./lb.

### METRIC BOLTS

Thread Size	Grade	Plated / Unplated
8mm-1.0 .....	8.8 .....	20 ft./lb. 18 ft./lb.
8mm-1.25 .....	8.8 .....	19 ft./lb. 18 ft./lb.
10mm-1.25 .....	8.8 .....	38 ft./lb. 36 ft./lb.
10mm-1.5 .....	8.8 .....	37 ft./lb. 35 ft./lb.

### METRIC BOLTS

Thread Size	Grade	Plated / Unplated
12mm-1.25 .....	8.8 .....	70 ft./lb. 65 ft./lb.
12mm-1.5 .....	8.8 .....	66 ft./lb. 61 ft./lb.
12mm-1.75 .....	8.8 .....	65 ft./lb. 60 ft./lb.
14mm-2.0 .....	8.8 .....	104 ft./lb. 97 ft./lb.

All illustrations and specifications contained herein are based on the latest information available at the time of publication approval. ROADMASTER, INC. reserves the right to make changes at any time without notice in material, specification and models or to discontinue models.





# BASEPLATE KIT INSTALLATION INSTRUCTIONS

**KIT# 1187-1A**

08/02/16  
KS

ROADMASTER, Inc. 6110 NE 127th Ave. Vancouver, WA 98682 360-896-0407 fax 360-735-9300 www.roadmasterinc.com

## Supplemental Instructions – 2011 Scion xB models

This supplement supersedes steps 1 through 5 in the mounting bracket installation instructions.

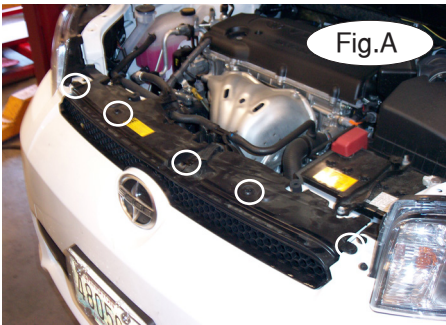

1. Remove five plastic fasteners attaching the radiator cover to the fascia and core support (Fig.A).
2. Remove three plastic fasteners and four 10mm screws attaching the top of the fascia to the core support (Fig.B).
3. On each side, remove one 10mm screw and one plastic fastener attaching the fender liner to the fender well (Fig.C).
4. On each side, remove four 10mm screws attaching the bottom of the fascia to the splash shield (Fig.D – driver's side).
5. Pull out and forward to remove the fascia (Fig.E). Disconnect the fog lights, if the vehicle is so equipped.

Now, proceed to step 6 in the regular instructions to finish the installation.

