



BASEPLATE KIT INSTALLATION INSTRUCTIONS

KIT# 523182-4

07/14/20
KS

ROADMASTER, Inc. 6110 NE 127th Ave. Vancouver, WA 98682 360-896-0407 fax 360-735-9300 www.roadmasterinc.com

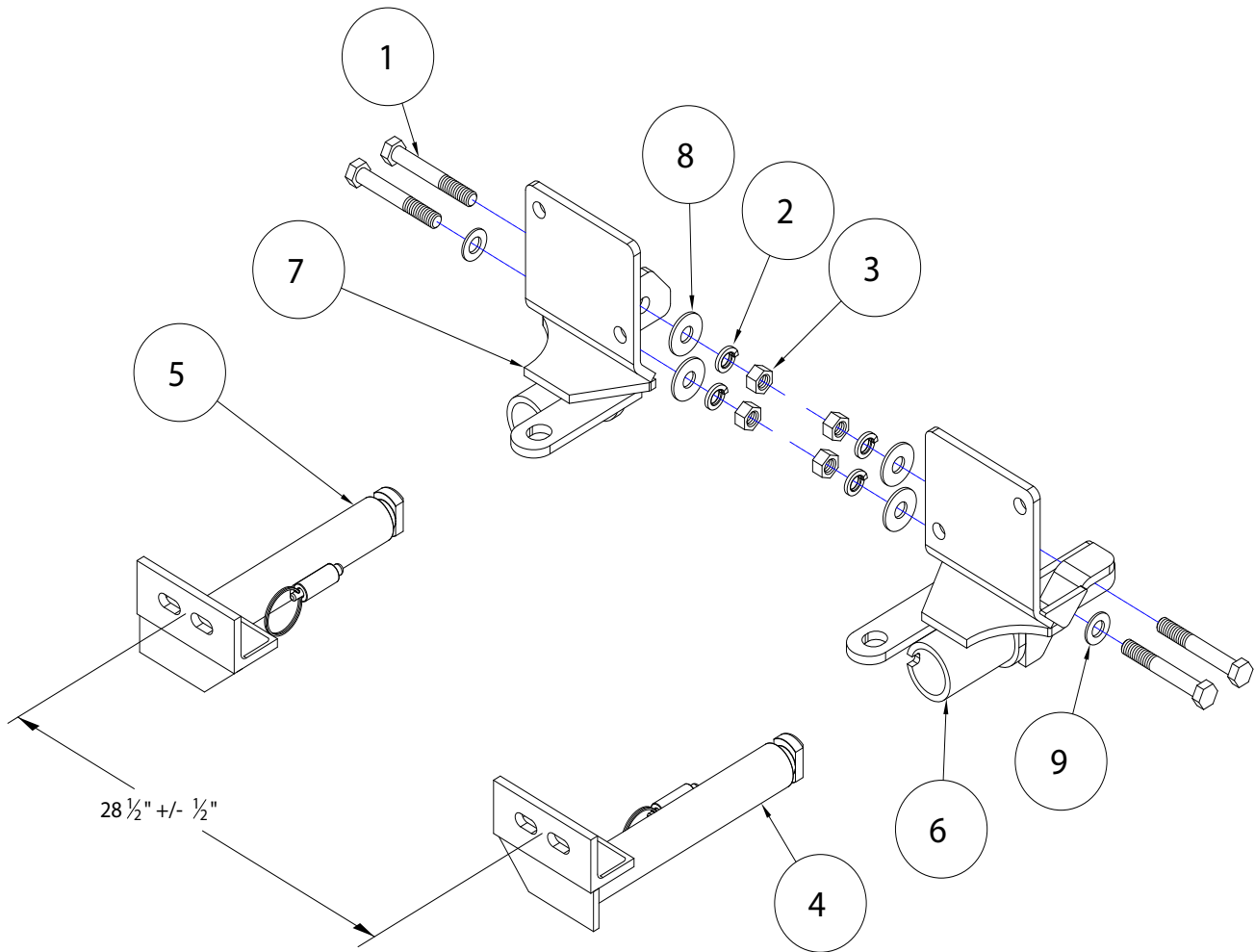

ITEM	QTY	NAME	PART #
1.....	4.....	1/2" x 3 1/2" BOLT	350103-00
2.....	4.....	1/2" LOCK WASHER.....	350309-00
3.....	4.....	1/2" HEX NUT.....	350258-00
4.....	1.....	DRIVER SIDE ARM.....	C002841
5.....	1.....	PASSENGER SIDE ARM.....	C002842
6.....	1.....	DRIVER SIDE RECEIVER.....	C002843
7.....	1.....	PASSENGER SIDE RECEIVER.....	C002844
8.....	4.....	1/2" FLAT WASHER.....	350308-00
9.....	2.....	1/2" SAE WASHER.....	350308-20



BASEPLATE KIT INSTALLATION INSTRUCTIONS

KIT# 523182-4

07/14/20
KS

ROADMASTER, Inc. 6110 NE 127th Ave. Vancouver, WA 98682 360-896-0407 fax 360-735-9300 www.roadmasterinc.com

This is one of our crossbar-style series kits, which allows the visible front portion of the baseplate to be easily removed from the front of the vehicle (Fig.A and Fig.B). The kit consists of a main receiver brace, two removable front braces, and a hardware pack.

The main receiver brace mounts to the frame rails. The removable front braces install in the main receiver brace.

Before starting the installation, lay out the kit components in order, as they will be used. This will give you a visual idea of how the components work, and will also confirm that everything is present and accounted for.



IMPORTANT: All baseplates **must** be assembled with all the bolts left loose for final adjustment and positioning (before tightening) unless otherwise instructed. All bolts **must** be torqued for proper strength. If more than one bolt is used per fastening point, the diagram may only show one. Use flat washers over all slotted holes and lock washers on all fasteners.

WARNING

Failure to heed these warnings or follow the installation instructions may result in a voided warranty, loss of towed vehicle, personal injury or death.

- Do not weld or modify this baseplate or its components. Welding or modification will void the warranty.
- Do not use this document as a basis to design/fabricate a baseplate, as it may not show all parts or structural components.
- We strongly recommend professional installation.
- If the towed vehicle has been in an accident, it must be properly repaired before attaching the baseplate. Do not install the baseplate if any structural frame damage is found.
- The installer must use all bolts and parts supplied. If running changes were made by the vehicle manufacturer after this kit was designed, some bolts or other fasteners may no longer be the correct size. It is the installer's responsibility to verify this kit is securely fastened to the vehicle.
- Use Loctite® Red on all bolts used to secure this baseplate. Torque all bolts to the specifications found at the end of these instructions. Do not over-torque the bolts or failure may occur.
- The installer must inspect the baseplate to ensure adequate clearance, particularly around hoses, air conditioner lines, radiators, etc. or non-warranty failure may result.
- Roadmaster manufactures many styles of baseplates. If your baseplate has removable arms, they must be removed before driving the vehicle, unless the arms can be pinned or padlocked in place. If not secured, the arms could vibrate out.
- Some motorhome chassis have such a tight turning radius that you can damage your motorhome, towed vehicle, tow bar or baseplate while turning sharply. Before getting on the road, test your turning radius in an empty parking lot. Turning too sharply could

result in non-warranty damage to your towing system, motorhome and/or towed vehicle.

- Do not back up with the towed vehicle attached or non-warranty damage will occur to your towing system or vehicles.
- The safety cables must connect the towing vehicle to the towed vehicle frame to frame, with the cables crossed, with enough slack for sharp turns. See cable instructions for proper routing. Failure to do so will result in non-warranty damage and/or the loss of the towed vehicle.
- This kit is designed for use with ROADMASTER tow bars and ROADMASTER adapters only. Using this kit with other brands, without an approved ROADMASTER adapter, may result in non-warranty damage or injury.
- Receiver extensions and out-of-level towing situations of 3 inches or more. This can cause the system to swing much higher and lower, causing excessive strain on the tow bar, baseplate and frame. That can cause the towing system to fail, causing property damage, personal injury or even death. If you must use a receiver extension or drop hitch to tow, it will reduce your receiver's weight capacity by 1/3 to avoid damaging your system. Never use more than one extension and/or drop hitch, as this will void your warranty.
- Every 3,000 miles, the owner must inspect all mounting points for cracks or fatigue, and check the fasteners for proper torque, according to the bolt torque requirements chart on the last page of these instructions.
- The owner must follow the vehicle manufacturer's instructions to prepare the vehicle for towing. Failure to do so may cause severe damage to the vehicle.
- This baseplate is only warranted for the original installation. Installing a used baseplate on another vehicle is not recommended and will void the warranty.



BASEPLATE KIT INSTALLATION INSTRUCTIONS

KIT# 523182-4

07/14/20
KS

ROADMASTER, Inc. 6110 NE 127th Ave. Vancouver, WA 98682 360-896-0407 fax 360-735-9300 www.roadmasterinc.com

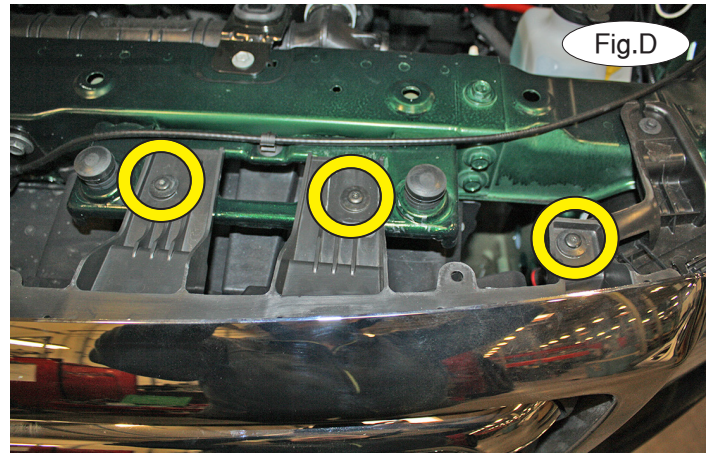
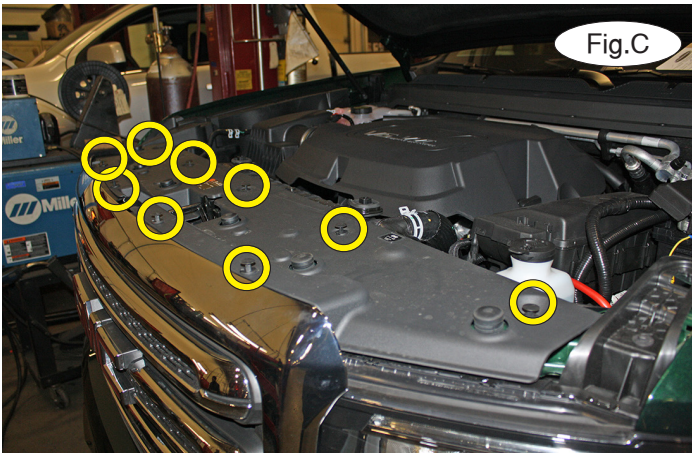

1. **Important:** please use all supplied bolts and parts and read all instructions carefully before beginning this installation. The majority of questions you may have can be answered within the text, and proper installation will ensure safe and secure travel. Now, begin the installation. **For Colorado models:** proceed to the next step. **For Canyon models:** remove nine plastic fasteners attaching the top of the radiator cover to the core support (Fig.C). Remove the radiator cover and set it aside for now.

2. **For '18 and later Colorado ZR2 models:** skip to the supplement on page 9 for fascia removal instructions. **For all other models:** on each side, remove three T15 Torx screws attaching the top of the fascia to the core support (Fig.D – driver's side). *Note:* Figure D depicts a GMC Canyon model. If you have a Chevrolet Colorado model, it may look slightly different but the same fastener removal still applies.

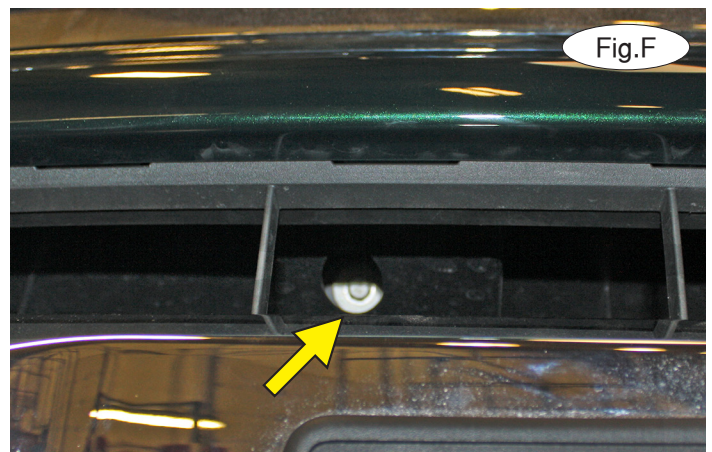

3. Locate the two spots indicated in Figure E. Place a 10mm extension through the center grille opening and remove two 10mm (head) bolts located above those two spots. Figure F shows the bolt head.

4. Remove four 15mm (head) bolts attaching the splash shielding to the frame (Fig.G).





BASEPLATE KIT INSTALLATION INSTRUCTIONS

KIT# 523182-4

07/14/20
KS

ROADMASTER, Inc. 6110 NE 127th Ave. Vancouver, WA 98682 360-896-0407 fax 360-735-9300 www.roadmasterinc.com



5. Remove two 10mm (head) bolts attaching the bottom of the fascia to the frame (Fig.H).

6. On each side, remove seven T15 Torx screws attaching the fender liner to the fascia (Fig.I and Fig.J). *Note:* if the vehicle is equipped with fender trim, some of these fasteners may be located under the trim and will need to be removed as well. Pull out the trim to locate them.



7. Pull out the fender liner and tuck it behind the tire. Disconnect the fog lights, if the vehicle is so equipped, and remove three 7mm (head) screws attaching the fender to the fascia (Fig.K).

8. On each side, pull down at the seam to release the aligning pins from the fascia (Fig.L).





BASEPLATE KIT INSTALLATION INSTRUCTIONS

KIT# 523182-4

07/14/20
KS

ROADMASTER, Inc. 6110 NE 127th Ave. Vancouver, WA 98682 360-896-0407 fax 360-735-9300 www.roadmasterinc.com

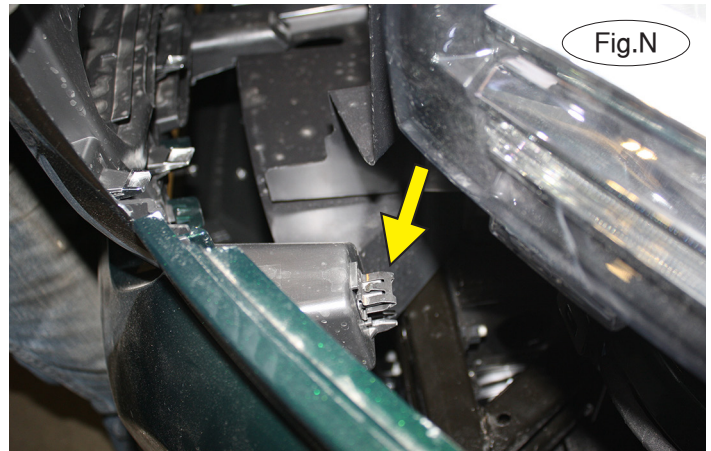

9. On each side, pull down to remove the fascia (Fig.M), releasing the clips on each side in the process (Fig.N).
10. Remove three plastic fasteners attaching the air dam to the frame rails (Fig.O) and on each side, one plastic clip (Fig.P – driver's side).

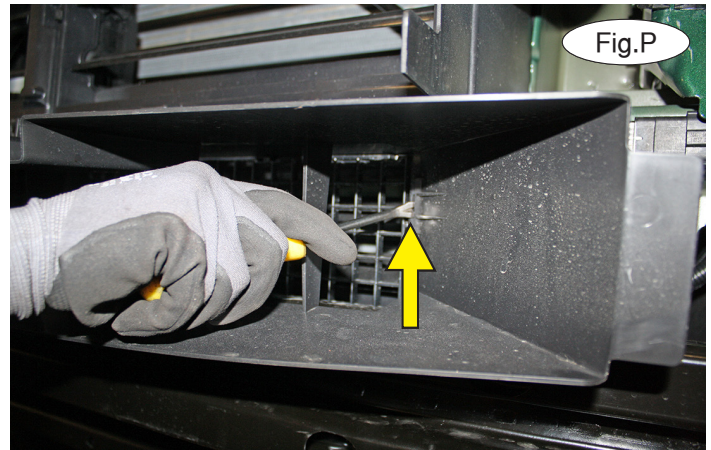
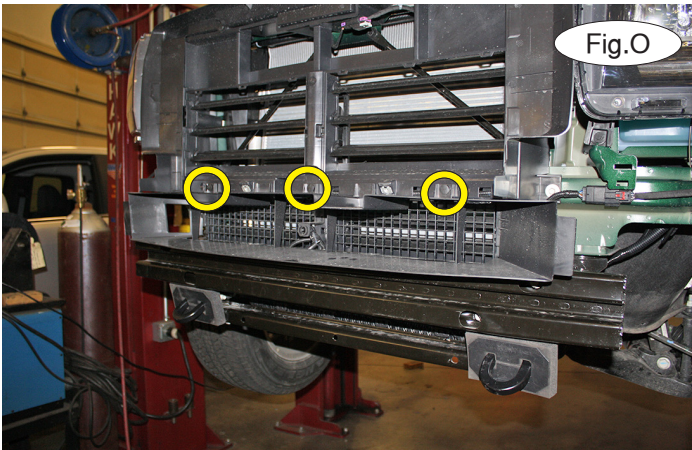

11. On each side, remove two 15mm (head) bolts attaching the bumper core to the frame (Fig.Q). Then, remove the foam covering and two 18mm (head) bolts and nuts attaching the tow hook to the frame. *Note:* the tow hooks will not be replaced. Retain the tow hooks and their hardware for replacement in case the bracket is ever removed.

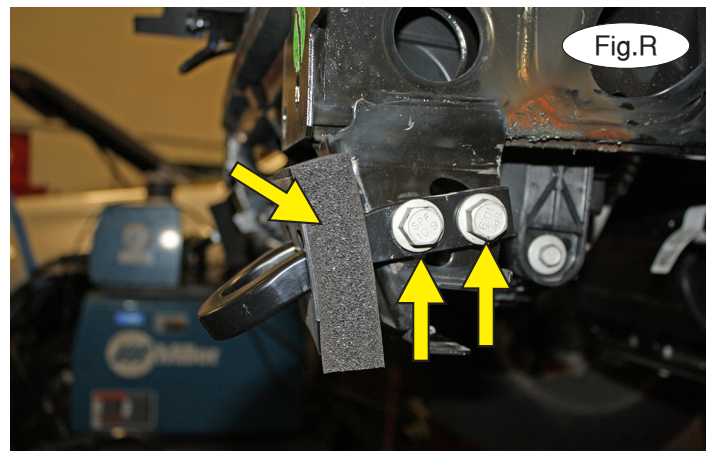
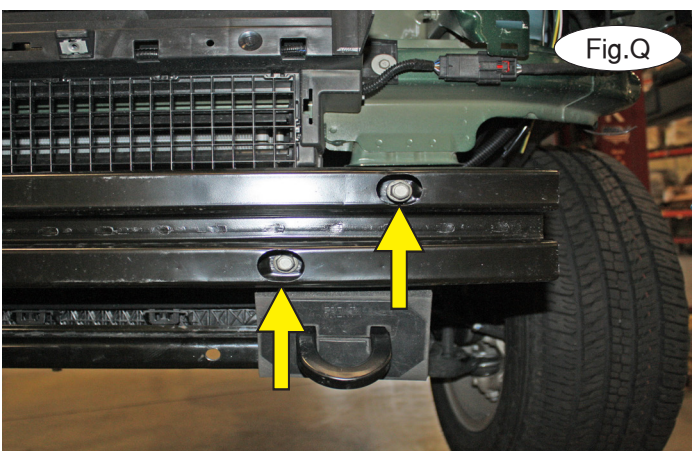



BASEPLATE KIT INSTALLATION INSTRUCTIONS

KIT# 523182-4

07/14/20
KS

ROADMASTER, Inc. 6110 NE 127th Ave. Vancouver, WA 98682 360-896-0407 fax 360-735-9300 www.roadmasterinc.com

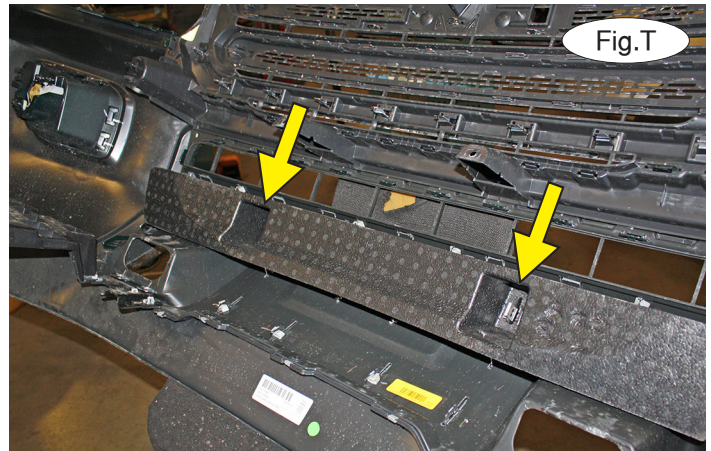
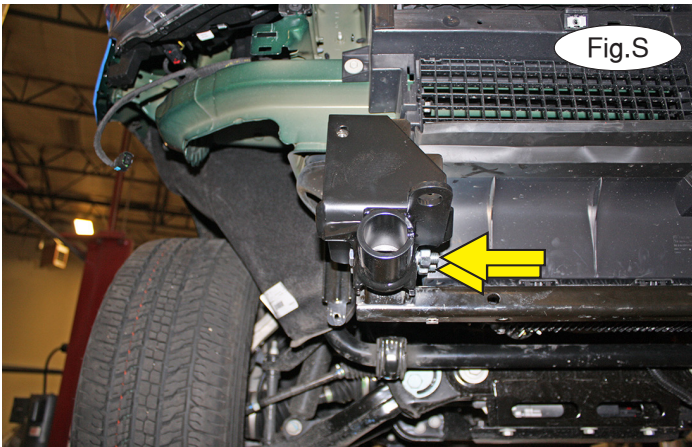

12. On each side, place the bracket around the tow hook mount and bolt it into place using two of the supplied $\frac{1}{2}$ " x $3\frac{1}{2}$ " bolts. *Note:* The forwardmost mount is slotted and will also need a $\frac{1}{2}$ " flat washer under the head of the bolt. Finish the bolts with two $\frac{1}{2}$ " lock washers and nuts (Fig.S). *Note: Ensure proper alignment, as the bolts will receive Loctite® Red and will be torqued at the end of these instructions.*

13. On the back of the fascia, remove two retaining clips attaching the foam shock absorption pad to the fascia (Fig.T). *Note:* the foam shock absorption pad will not be replaced. Retain the pad and its hardware for replacement in case the bracket is ever removed.

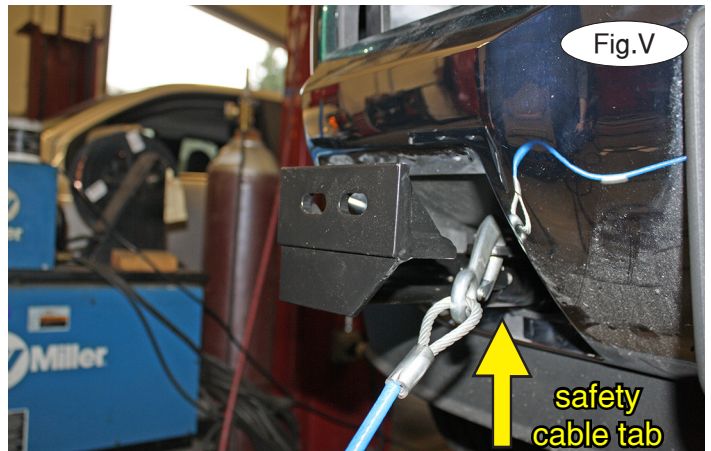

14. Replace the bumper core and its bolts over the top of the bracket. Use the drawing on page 1 as a guide to ensure the bracket is centered on the car and that the attachment points for the quick-disconnects are $28\frac{1}{2}$ " from center to center. Then, tighten all bolts to the bolt torque requirements found at the end of these instructions. *Note: use Loctite Red on all nuts and bolts.*

15. Trim the fascia as shown (Fig.U – driver's side). *Note:* models with tow hooks will only need to trim the yellow lines indicated. Models without tow hooks will need to trim the entire hole. **For ZR2 models:** return to the supplement on page 10 to finish reassembling the fascia.

16. On each side, insert the removable front arm into the front receiver 90 degrees from its final towing position, depressing the spring-loaded pin against the receiver. Twist back 90 degrees until the spring-loaded pin snaps into place in the notch on the receiver, locking the arm into place in its final towing position.

Please note: it is the owner's responsibility to ensure the locking of the pins before towing. Otherwise, failure of the towing system will result.

IMPORTANT!

Safety cables are required by law. When towing, connect safety cables to the safety cable tabs illustrated on the first page and in Figure V. Make certain there is adequate slack in the cables to allow a full turning radius; otherwise, damage will result. If necessary, longer cables or cable extensions are available.



BASEPLATE KIT INSTALLATION INSTRUCTIONS

KIT# 523182-4

07/14/20
KS

ROADMASTER, Inc. 6110 NE 127th Ave. Vancouver, WA 98682 360-896-0407 fax 360-735-9300 www.roadmasterinc.com

Three options for attaching the wiring plug to the main receiver brace

For six-wire plugs: use the two supplied 3/4" self-tapping screws to attach the electrical plug directly to the rods on the front of the main receiver brace.

For four-wire round plugs: attach to the plug mounting plate and then use the two supplied 3/4" self-tapping screws to attach the mounting plate to the rods on the front of the main receiver brace.

For four-wire flat plugs: place the plug through the mounting plug plate, and then secure it using the supplied zip tie on the front of the plug (Fig.W). Use the two supplied 3/4" self-tapping screws to attach the mounting plate to the rods on the front of the main receiver brace.

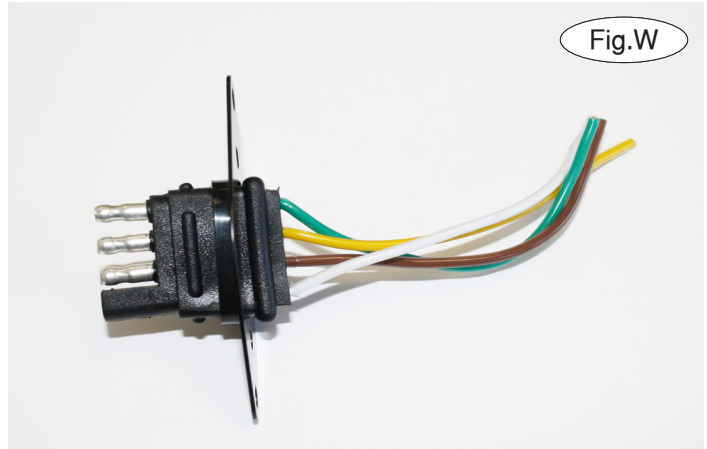

BOLT TORQUE REQUIREMENTS

Note: The torque values represented below are intended as general guidelines. Torque requirements for specific applications may vary. Roadmaster does not warrant this information to be accurate for all applications and disclaims all liability for any claims or damages which may result from its use.

STANDARD BOLTS

Thread Size	Grade	Torque
5/16-18	5	13 ft./lb.
3/8-16	5	23 ft./lb.
7/16-14	5	37 ft./lb.
1/2-13	5	57 ft./lb.
5/8-11	5	112 ft./lb.

METRIC BOLTS

Thread Size	Grade	Torque
6mm-1.0	8.8	6 ft./lb.
8mm-1.0	8.8	18 ft./lb.
8mm-1.25	8.8	16 ft./lb.
10mm-1.25	8.8	36 ft./lb.
10mm-1.5	8.8	31 ft./lb.

METRIC BOLTS

Thread Size	Grade	Torque
12mm-1.25	8.8	64 ft./lb.
12mm-1.5	8.8	60 ft./lb.
12mm-1.75	8.8	55 ft./lb.
14mm-2.0	8.8	88 ft./lb.

All illustrations and specifications contained herein are based on the latest information available at the time of publication approval. ROADMASTER, INC. reserves the right to make changes at any time without notice in material, specification and models or to discontinue models.



BASEPLATE KIT INSTALLATION INSTRUCTIONS

KIT# 523182-4

07/14/20
KS

ROADMASTER, Inc. 6110 NE 127th Ave. Vancouver, WA 98682 360-896-0407 fax 360-735-9300 www.roadmasterinc.com

For '18 and later Colorado ZR2 models only: follow the instructions below to remove the fascia and skidplate.

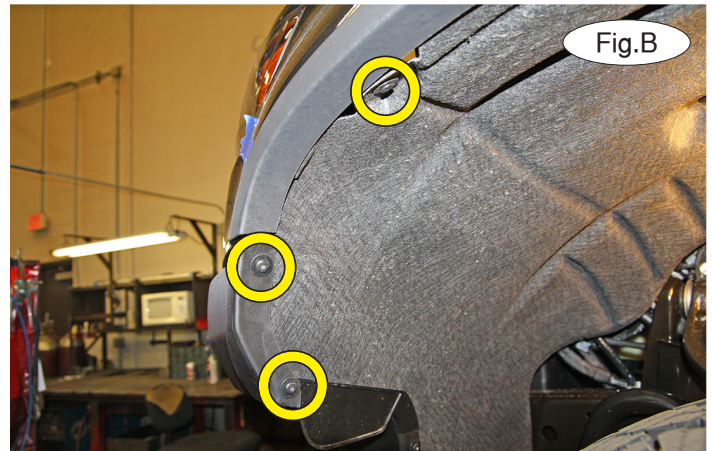
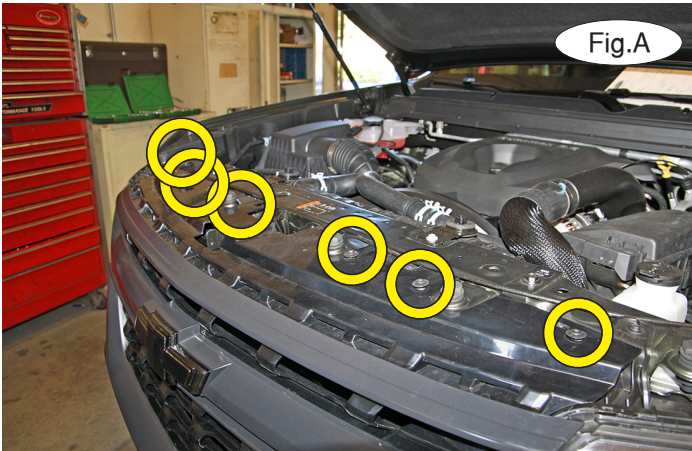

1. On each side, remove six T15 Torx screws attaching the fascia to the core support (Fig.A).
2. On each side, remove seven T15 Torx screws and one 7mm (head) bolt attaching the fender liner and the fascia to the frame (Fig.B and C). Then, remove one additional T15 Torx screw on the front of the fender liner (Fig.C – inset).

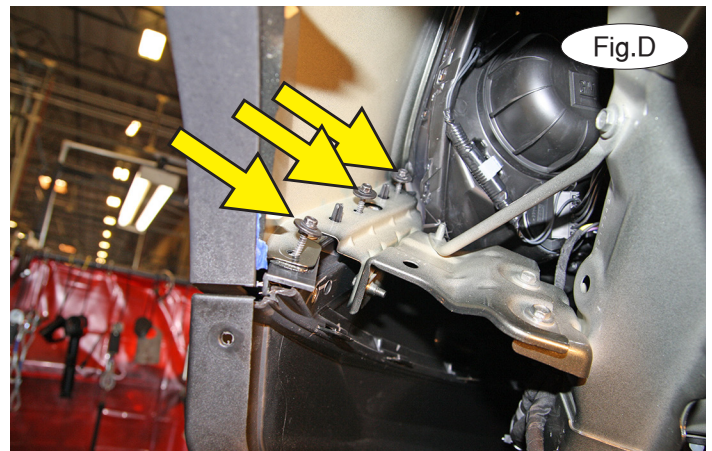

3. On each side, push back the fender liner and remove three 7mm screws attaching the fascia to the fender (Fig.D).

4. On each side, remove two 10mm (head) bolts attaching the lower fascia to the radiator support (Fig.E).

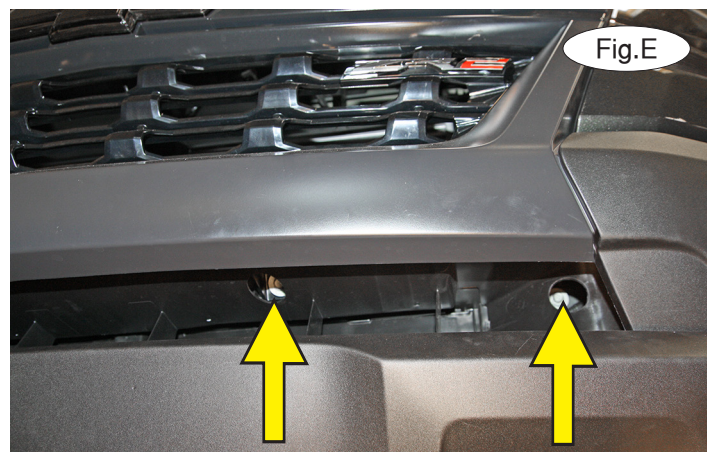



BASEPLATE KIT INSTALLATION INSTRUCTIONS

KIT# 523182-4

07/14/20
KS

ROADMASTER, Inc. 6110 NE 127th Ave. Vancouver, WA 98682 360-896-0407 fax 360-735-9300 www.roadmasterinc.com

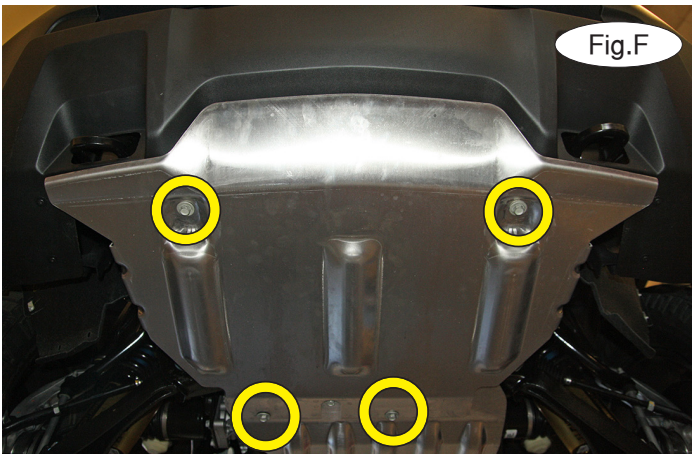

5. On each side, remove two 15mm (head) bolts attaching the front skid plate to the frame. Then, loosen the two rear 15mm (head) bolts attaching the front plate to the rear skid plate to remove it (Fig.F). *Note:* if you plan to use a breakaway and/or our wiring plug mounts, you will need to trim the skid plate as shown in Figure G.

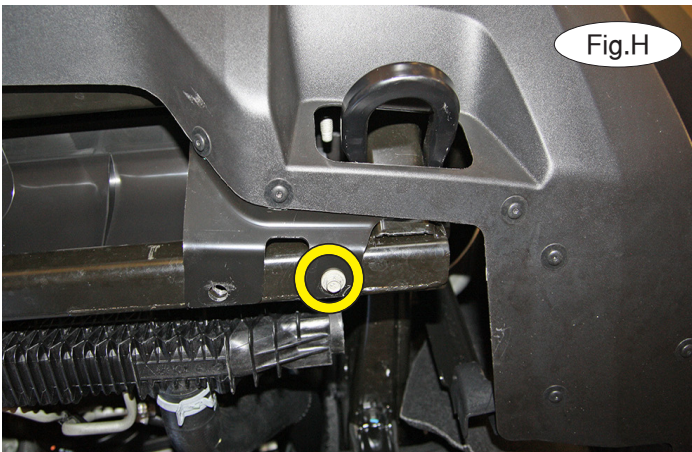

6. On each side, remove one 10mm (head) bolt attaching the fascia to the radiator support (Fig.H).

7. On each side, pull out the trim piece to release all of the clips (Fig.I). Then, pull up on the top of the fascia before pulling down, perpendicular to the frame, to release the fascia aligning pins (Fig.J). Unplug the emblem lights and the fog lights, if the vehicle is so equipped.



Now, return to step 10 in the regular installation instructions to finish installing the bracket, before returning here after step 15 to reassemble the fascia and skid plate by reversing steps 1 through 7.