

BASEPLATE KIT INSTALLATION INSTRUCTIONS

ROADMASTER, Inc. 6110 NE 127th Ave. Vancouver, WA 98682 360-896-0407 fax 360-735-9300 www.roadmasterinc.com

PARTS LIST:

- 2- BACKING PLATE (1)
- 1- MAIN BRACE (2)- Passenger side
- 1- MAIN BRACE (3)- Driver's side

KIT NO. 118-1

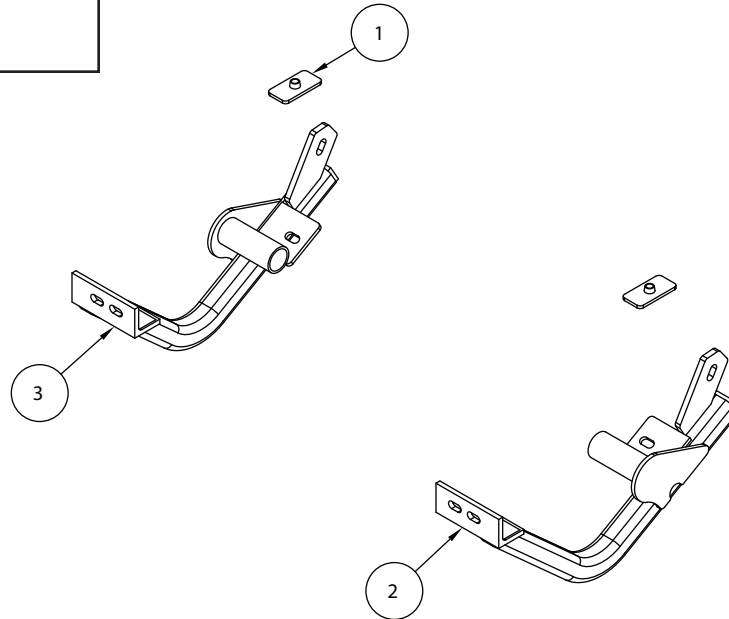

04-11-17

IMPORTANT: All baseplates **must** be assembled with all the bolts left loose for final adjustment and positioning (before tightening) unless otherwise instructed. All bolts **must** be torqued for proper strength. If more than one bolt is used per fastening point, the diagram may only show one. Use flat washers over all slotted holes and lock washers on all fasteners.

WARNING

Failure to heed these warnings or follow the installation instructions may result in a voided warranty, loss of towed vehicle, personal injury or death.

- Do not weld or modify this baseplate or its components. Welding or modification will void the warranty.
- Do not use this document as a basis to design/fabricate a baseplate, as it may not show all parts or structural components.
- We strongly recommend professional installation.
- If the towed vehicle has been in an accident, it must be properly repaired before attaching the baseplate. Do not install the baseplate if any structural frame damage is found.
- The installer must use all bolts and parts supplied. If running changes were made by the vehicle manufacturer after this kit was designed, some bolts or other fasteners may no longer be the correct size. It is the installer's responsibility to verify this kit is securely fastened to the vehicle.
- Use Loctite® Red on all bolts used to secure this baseplate. Torque all bolts to the specifications found at the end of these instructions. Do not over-torque the bolts or failure may occur.
- The installer must inspect the baseplate to ensure adequate clearance, particularly around hoses, air conditioner lines, radiators, etc. or non-warranty failure may result.
- Roadmaster manufactures many styles of baseplates. If your baseplate has removable arms, they must be removed before driving the vehicle, unless the arms can be pinned or padlocked in place. If not secured, the arms could vibrate out.
- Some motorhome chassis have such a tight turning radius that you can damage your motorhome, towed vehicle, tow bar or baseplate while turning sharply. Before getting on the road, test your turning radius in

an empty parking lot. Turning too sharply could result in non-warranty damage to your towing system, motorhome and/or towed vehicle.

- Do not back up with the towed vehicle attached or non-warranty damage will occur to your towing system or vehicles.
- The safety cables must connect the towing vehicle to the towed vehicle frame to frame, with the cables crossed, with enough slack for sharp turns. See cable instructions for proper routing. Failure to do so will result in non-warranty damage and/or the loss of the towed vehicle.
- This kit is designed for use with ROADMASTER tow bars and ROADMASTER adapters only. Using this kit with other brands, without an approved ROADMASTER adapter, may result in non-warranty damage or injury.
- Receiver extensions and out-of-level towing situations of 3 inches or more. This can cause the system to swing much higher and lower, causing excessive strain on the tow bar, baseplate and frame. That can cause the towing system to fail, causing property damage, personal injury or even death. If you must use a receiver extension or drop hitch to tow, it will reduce your receiver's weight capacity by 1/3 to avoid damaging your system. Never use more than one extension and/or drop hitch, as this will void your warranty.
- Every 3,000 miles, the owner must inspect all mounting points for cracks or fatigue, and check the fasteners for proper torque, according to the bolt torque requirements chart on the last page of these instructions.
- The owner must follow the vehicle manufacturer's instructions to prepare the vehicle for towing. Failure to do so may cause severe damage to the vehicle.
- This baseplate is only warranted for the original installation. Installing a used baseplate on another vehicle is not recommended and will void the warranty.

BASEPLATE KIT INSTALLATION INSTRUCTIONS

ROADMASTER, Inc. 6110 NE 127th Ave. Vancouver, WA 98682 360-896-0407 fax 360-735-9300 www.roadmasterinc.com

KIT NO. 118-1

- Important:** please use all supplied bolts and parts and read all instructions carefully before beginning this installation. The majority of questions you may have can be answered within the text, and proper installation will ensure safe and secure travel. Now, begin the installation. This bracket kit utilizes the front frame crossover tube, the front tow loop and both side frame tubes as main mounting points. Remove the splash guard on the passenger side.
- Now insert the two main braces into the front frame crossover tube and position with the rear of the brace against the sides of the frame tubes and the bottom mounting plates tight against the bottom of the frame.
- The braces should be positioned so that the flat mounting tab is tight against the bottom of the frame and the hole is centered in the bottom of the frame rail. A 1/2" hole should be drilled in the center of the frame rail at this time. *Note:* be sure to drill the hole in the hole in the center of the frame rail otherwise you won't be able to line up the threaded backup plates which must be inserted through the front of the frame rail. Once the hole is drilled, locate the threaded 3/16" x 1 1/2" x 3" backing plate, a 1/2" x 1 1/2" bolt, flat washer and lock washer. Insert the backing plate in the front of the frame and bolt through the brace, and frame into the backing plate.
- Using the drawing on the first page as a reference, measure between the two front braces, ensuring that the distance is still 28 1/2" +/- 1/2".
- Now, drill a 1/2" hole through the frame rail on each side using the rear most hole in each brace as a guide. Take a 1/2" x 3 1/2" bolt and flat washer, then bolt through the brace and frame finishing with a plate washer, lock washer and nut. The driver's side takes the clipped plate washer. *Note:* do not over-tighten these bolts. When applying torque to any bolt, care must be taken not to crush or deform frame or body parts. If crushing or deformation of the frame or body parts begins to occur, proper torque may be determined by the flattening of the lock washers and initial flexing of the frame.
- Torque all bolts to the torque requirements below. Re-check the measurements between the braces, to make certain this distance is still 28 1/2" +/- 1/2".

Hardware

- 2- 1/2" x 1-1/2" bolt
- 2- 1/2" x 3-1/2" bolts
- 1- 1/2" plate washer
- 1- 1/2" clipped plate washer
- 2- 3/16" x 1-1/2" x 3" threaded backing plates
- 4- 1/2" flat washers
- 2- 1/2" nuts
- 4- 1/2" lock washers

04-11-17

also available: 118-1HK hardware kit (includes all bolts, washers and miscellaneous parts listed above)

BOLT TORQUE REQUIREMENTS

Note: The torque values represented below are intended as general guidelines. Torque requirements for specific applications may vary. Roadmaster does not warrant this information to be accurate for all applications and disclaims all liability for any claims or damages which may result from its use.

STANDARD BOLTS			METRIC BOLTS			METRIC BOLTS		
Thread Size	Grade	Torque	Thread Size	Grade	Plated / Unplated	Thread Size	Grade	Plated / Unplated
5/16	5	13 ft./lb.	8mm-1.0	8.8	20 ft./lb. 18 ft./lb.	12mm-1.25	8.8	70 ft./lb. 65 ft./lb.
3/8	5	23 ft./lb.	8mm-1.25	8.8	19 ft./lb. 18 ft./lb.	12mm-1.5	8.8	66 ft./lb. 61 ft./lb.
7/16	5	37 ft./lb.	10mm-1.25	8.8	38 ft./lb. 36 ft./lb.	12mm-1.75	8.8	65 ft./lb. 60 ft./lb.
1/2	5	56 ft./lb.	10mm-1.5	8.8	37 ft./lb. 35 ft./lb.	14mm-2.0	8.8	104 ft./lb. 97 ft./lb.
5/8	5	150 ft./lb.						