

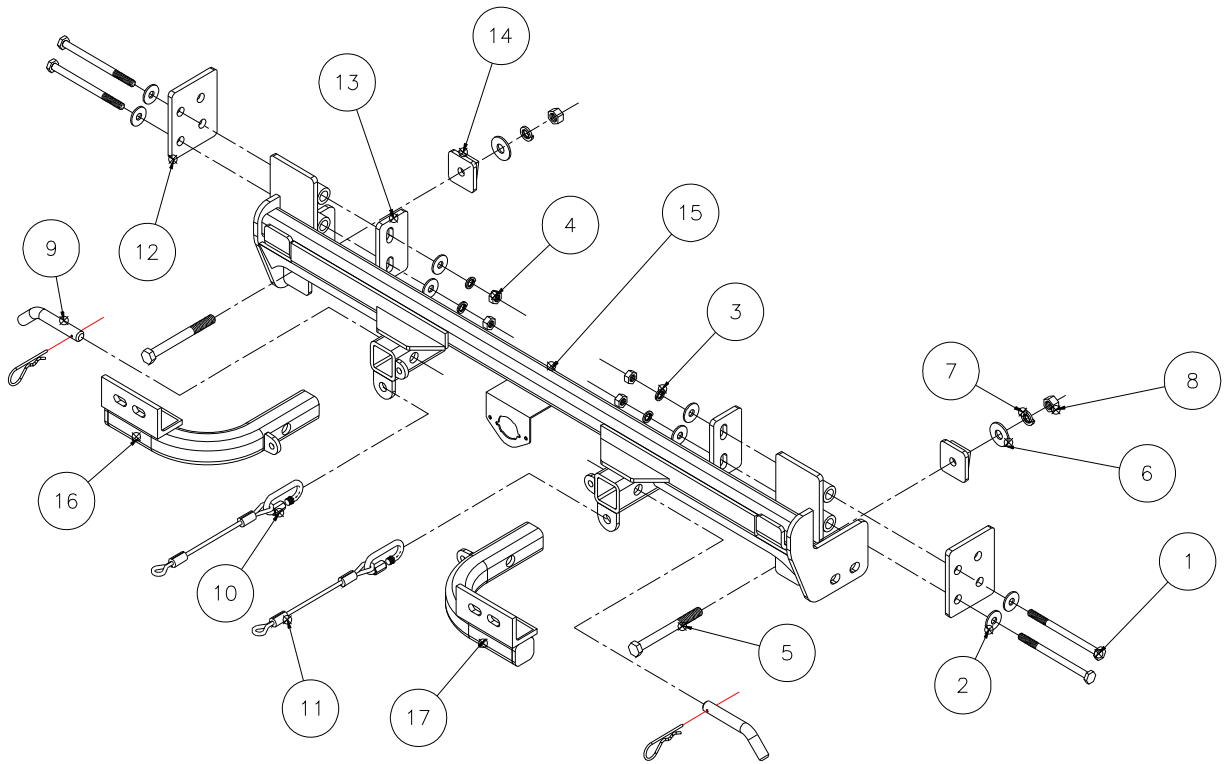

# BASEPLATE KIT INSTALLATION INSTRUCTIONS

**KIT# 4401-1**  
11/29/07  
KS

ROADMASTER, Inc. 6110 NE 127th Ave. Vancouver, WA 98682 1-800-669-9690 fax 360-735-9300 www.roadmasterinc.com



ITEM	QTY	NAME	MATERIAL
1	4	10mm x 1.5 x 140mm BOLT	356124-00
2	8	FENDER WASHER	355716-00
3	4	LOCK WASHER	355715-00
4	4	10mm x 1.5 NUT	356230-00
5	2	1/2" x 5 1/2" BOLT	350108-00
6	2	FLAT WASHER	350308-20
7	2	LOCK WASHER	350309-00
8	2	NUT	350258-00
9	2	DRAW PIN, SPRING PIN	357035-00
10	2	CABLE CONNECTOR	200008-00
11	2	SAFETY CABLE	500646-08
12	2	BACKING PLATE	A-000447
13	2	BACKING PLATE	A-000446
14	2	BEVELED WASHER	C-000232
15	1	MAIN BRACE	C-000951
16	1	PASSENGER SIDE ARM WELDMENT	C-000953
17	1	DRIVER SIDE ARM WELDMENT	C-000952



# BASEPLATE KIT INSTALLATION INSTRUCTIONS

**KIT# 4401-1**

11/29/07  
KS

ROADMASTER, Inc. 6110 NE 127th Ave. Vancouver, WA 98682 1-800-669-9690 fax 360-735-9300 www.roadmasterinc.com

This is one of our XL bracket series, which allows the visible front portion of the bracket to be easily removed from the front of the car by removing the front braces. The bracket kit consists of a receiver brace, two front braces, and a hardware pack. The rear receiver brace mounts to the front of the frame and protrudes through the lower grill below the headlights. The bumper core is removed and replaced with the receiver brace. The front braces insert into the rear brace and pin in place. Before starting the installation, lay out the kit components as it is illustrated. This will give you a visual idea of how the components work and also confirm that everything is present and accounted for.



**IMPORTANT:** All baseplates **must** be assembled with all the bolts left loose for final adjustment and positioning (before tightening) unless otherwise instructed. All bolts **must** be torqued for proper strength. If more than one bolt is used per fastening point, the diagram may only show one. Use flat washers over all slotted holes and lock washers on all fasteners.

## WARNING

Failure to heed these warnings or follow the installation instructions may result in a voided warranty, loss of towed vehicle, personal injury or death.

- Do not weld or modify this baseplate or its components. Welding or modification will void the warranty.
- Do not use this document as a basis to design/fabricate a baseplate, as it may not show all parts or structural components.
- We strongly recommend professional installation.
- If the towed vehicle has been in an accident, it must be properly repaired before attaching the baseplate. Do not install the baseplate if any structural frame damage is found.
- The installer must use all bolts and parts supplied. If running changes were made by the vehicle manufacturer after this kit was designed, some bolts or other fasteners may no longer be the correct size. It is the installer's responsibility to verify this kit is securely fastened to the vehicle.
- Use Loctite® Red on all bolts used to secure this baseplate. Torque all bolts to the specifications found at the end of these instructions. Do not over-torque the bolts or failure may occur.
- The installer must inspect the baseplate to ensure adequate clearance, particularly around hoses, air conditioner lines, radiators, etc. or non-warranty failure may result.
- Roadmaster manufactures many styles of baseplates. If your baseplate has removable arms, they must be removed before driving the vehicle, unless the arms can be pinned or padlocked in place. If not secured, the arms could vibrate out.
- Some motorhome chassis have such a tight turning radius that you can damage your motorhome, towed vehicle, tow bar or baseplate while turning sharply. Before getting on the road, test your turning radius in an empty parking lot. Turning too sharply could result in non-warranty damage to your towing system, motorhome and/or towed vehicle.
- Do not back up with the towed vehicle attached or non-warranty damage will occur to your towing system or vehicles.
- The safety cables must connect the towing vehicle to the towed vehicle frame to frame, with the cables crossed, with enough slack for sharp turns. See cable instructions for proper routing. Failure to do so will result in non-warranty damage and/or the loss of the towed vehicle.
- This kit is designed for use with ROADMASTER tow bars and ROADMASTER adapters only. Using this kit with other brands, without an approved ROADMASTER adapter, may result in non-warranty damage or injury.
- Receiver extensions and out-of-level towing situations of 3 inches or more. This can cause the system to swing much higher and lower, causing excessive strain on the tow bar, baseplate and frame. That can cause the towing system to fail, causing property damage, personal injury or even death. If you must use a receiver extension or drop hitch to tow, it will reduce your receiver's weight capacity by 1/3 to avoid damaging your system. Never use more than one extension and/or drop hitch, as this will void your warranty.
- Every 3,000 miles, the owner must inspect all mounting points for cracks or fatigue, and check the fasteners for proper torque, according to the bolt torque requirements chart on the last page of these instructions.
- The owner must follow the vehicle manufacturer's instructions to prepare the vehicle for towing. Failure to do so may cause severe damage to the vehicle.
- This baseplate is only warranted for the original installation. Installing a used baseplate on another vehicle is not recommended and will void the warranty.



# BASEPLATE KIT INSTALLATION INSTRUCTIONS

**KIT# 4401-1**  
11/29/07  
KS

ROADMASTER, Inc. 6110 NE 127th Ave. Vancouver, WA 98682 1-800-669-9690 fax 360-735-9300 www.roadmasterinc.com



Fig.B

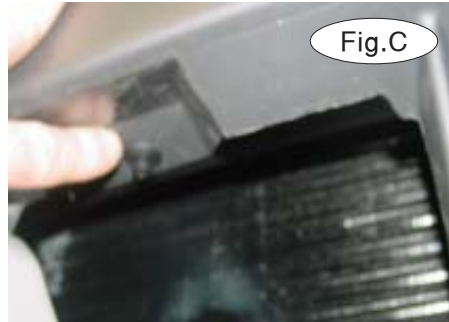

Fig.C



Fig.D



Fig.E



Fig.F



Fig.G

1. **Important:** please use all supplied bolts and parts and read all instructions carefully before beginning this installation. The majority of questions you may have can be answered within the text, and proper installation will ensure safe and secure travel. Now, begin the installation by removing the front fascia, starting with two 10mm (head) bolts located on the top near the inside corners of the headlights (Fig.B), then two plastic fasteners in the lower grille opening (Fig.C). Move to the fender wells and remove three plastic fasteners in each fender well (Fig.D).

Remove three 10mm (head) bolts from the bottom of the fascia in front of the fender wells on each side, then remove three more across the bottom of the fascia (Fig.E).

Now, go to the fascia fender joints and remove one plastic fastener in each side (Fig.F). Disconnect the foglights (Fig.G) and pull forward to remove (Fig.I). Set the fascia aside.

2. Remove two plastic fasteners from the radiator air deflectors on each side (Fig.I) and remove (Fig.J).
3. Remove the bumper core (four 13mm nuts, two on each side – Fig.K,L).



Fig.H

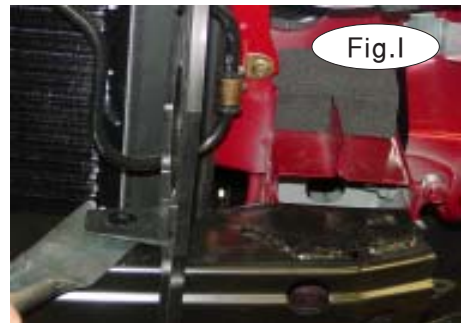

Fig.I



Fig.J

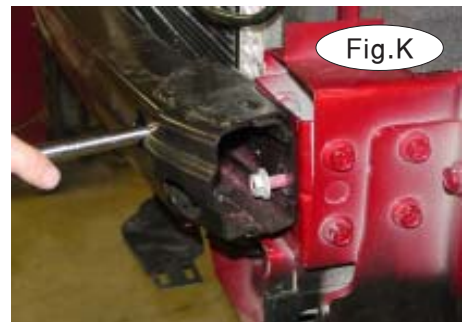

Fig.K



# BASEPLATE KIT INSTALLATION INSTRUCTIONS

**KIT# 4401-1**  
11/29/07  
KS

ROADMASTER, Inc. 6110 NE 127th Ave. Vancouver, WA 98682 1-800-669-9690 fax 360-735-9300 www.roadmasterinc.com

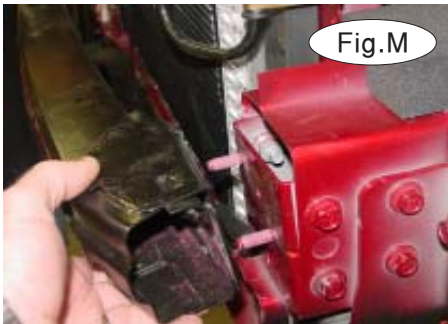

Fig.M



Fig.N

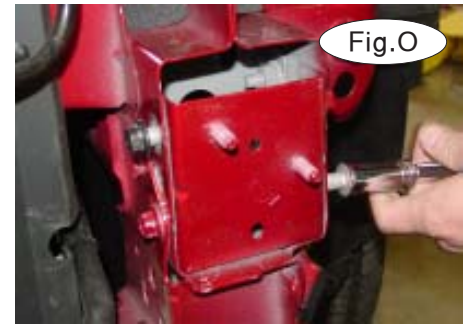

Fig.O

4. Now remove the tie down brackets (five 13mm head bolts) on each side (Fig.N), then remove the bumper core support brackets in front of the frame tubes (four 13mm head bolts) on each side (Fig.O).

Note: the main receiver brace will replace all the parts removed in steps 3 and 4 except some of the bolts, which will be reused (Fig.P).

Note: retain the bumper core and attachment hardware so that it can be replaced if the bracket is ever removed.



Fig.P



Fig.Q

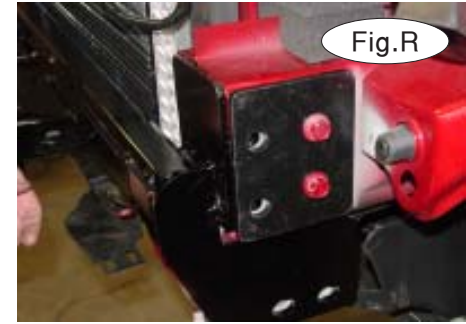

Fig.R

5. Mount the main receiver brace in the front of the frame tubes (Fig.Q) with a outside backing plate and two original bolts (Fig.R).



Fig.S



Fig.T



Fig.U

6. Use two more existing bolts in the lower mounting holes on each side (Fig.S) and tighten to hold in position.

7. Bolt through the top front frame mounting holes, the outside backing plate and an inner backing plate with two 10mm x 1.5 x 140mm bolts, fender washers, lock washers and nuts on each side (Fig.T,U,V).



# BASEPLATE KIT INSTALLATION INSTRUCTIONS

**KIT# 4401-1**  
11/29/07  
KS

ROADMASTER, Inc. 6110 NE 127th Ave. Vancouver, WA 98682 1-800-669-9690 fax 360-735-9300 www.roadmasterinc.com

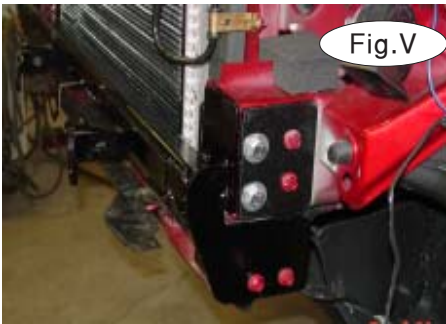

Fig.V



Fig.W

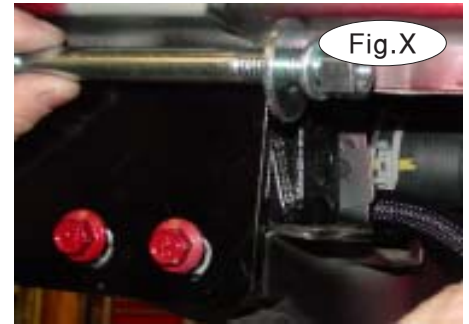

Fig.X

8. Using the main receiver brace as a drill template, drill a 17/32" hole through the front of the frame on each side (Fig.W).
9. Bolt through these holes with a 1/2" x 5-1/2" bolt, beveled backing plate, flat washer, lock washer and nut (Fig.X).
10. Align the brace, then torque all mounting bolts to the specifications at the bottom of these instructions.
11. Trim the front radiator air deflectors as shown, then reinstall (Fig.Y).
12. Once the trimming is done, reinstall the fascia, reversing step 1, with the exception of replacing the bumper core and the parts removed in step 4.

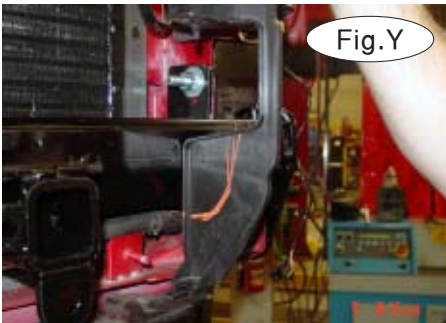

Fig.Y



Fig.Z



Fig.AA

13. Install the front braces by inserting them into the front of the receivers and pinning them in place with 5/8" draw pins and 1/8" spring pins (Fig.Z).
14. Mount the tow bar according to the tow bar manufacturer's instructions. Install the 8" safety cables under the main receivers with the quick links provided (Fig.AA, BB). Attach the other end to the tow vehicle's safety cables and tow bar.

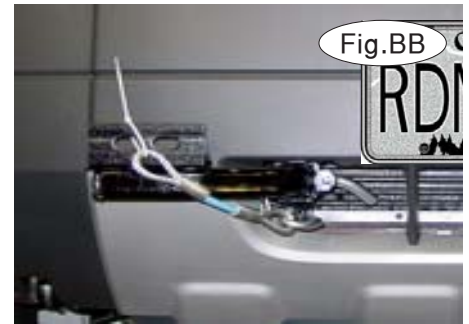

Fig.BB

## BOLT TORQUE REQUIREMENTS

Note: The torque values represented below are intended as general guidelines. Torque requirements for specific applications may vary. Roadmaster does not warrant this information to be accurate for all applications and disclaims all liability for any claims or damages which may result from its use.

### STANDARD BOLTS

Thread Size	Grade	Torque
5/16	5	13 ft./lb.
3/8	5	23 ft./lb.
7/16	5	37 ft./lb.
1/2	5	56 ft./lb.
5/8	5	150 ft./lb.

### METRIC BOLTS

Thread Size	Grade	Plated/Unplated
8mm-1.0	8.8	20 ft./lb. 18 ft./lb.
8mm-1.25	8.8	19 ft./lb. 18 ft./lb.
10mm-1.25	8.8	38 ft./lb. 36 ft./lb.
10mm-1.5	8.8	37 ft./lb. 35 ft./lb.

### METRIC BOLTS

Thread Size	Grade	Plated/Unplated
12mm-1.25	8.8	70 ft./lb. 65 ft./lb.
12mm-1.5	8.8	66 ft./lb. 61 ft./lb.
12mm-1.75	8.8	65 ft./lb. 60 ft./lb.
14mm-2.0	8.8	104 ft./lb. 97 ft./lb.

All illustrations and specifications contained herein are based on the latest information available at the time of publication approval. ROADMASTER, INC. reserves the right to make changes at any time without notice in material, specification and models or to discontinue models.