



BASEPLATE KIT INSTALLATION INSTRUCTIONS

KIT# 521446-5

05/23/23
KS

ROADMASTER, Inc. 6110 NE 127th Ave. Vancouver, WA 98682 360-896-0407 fax 360-735-9300 www.roadmasterinc.com

*Special tools needed:
plastic pop rivet gun*

Important

Note: This baseplate will not accommodate the Guardian rock shield, some models of the Tow Defender, Stowaway or the StowMaster and StowMaster All Terrain tow bars.

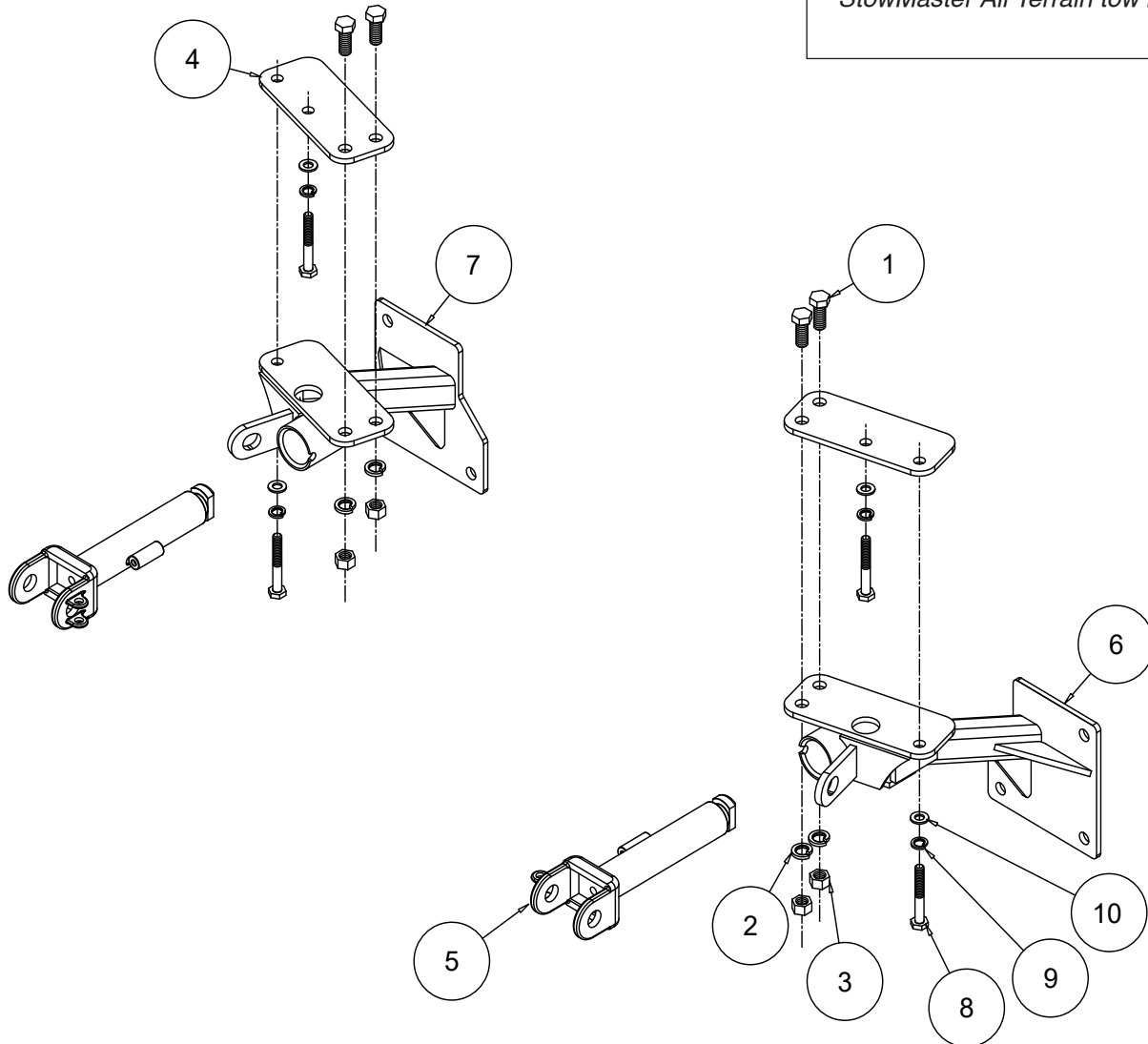

ITEM	QTY	NAME	PART #
1.....	4.....	1/2" x 1 1/4" BOLT	350094-00
2.....	4.....	1/2" LOCK WASHER.....	350309-00
3.....	4.....	1/2" HEX NUT.....	350258-00
4.....	2.....	SPACER PLATE.....	A004561
5.....	2.....	ARM.....	C002383
6.....	1.....	DRIVER SIDE RECEIVER.....	C002688
7.....	1.....	PASSENGER SIDE RECEIVER	C002689
8.....	4.....	M10 x 1.5 x 65 mm BOLT.....	356117-00
9.....	4.....	M10 LOCK WASHER.....	355715-00
10.....	4.....	3/8" FLAT WASHER.....	350304-00
11.....	2.....	PLASTIC POP RIVET	350341-00



BASEPLATE KIT INSTALLATION INSTRUCTIONS

KIT# 521446-5

05/23/23
KS

ROADMASTER, Inc. 6110 NE 127th Ave. Vancouver, WA 98682 360-896-0407 fax 360-735-9300 www.roadmasterinc.com

This is one of our direct-connect series kits, which allows the visible front portion of the baseplate to be easily removed from the front of the vehicle (Fig.A and Fig.B). The kit consists of two main receiver braces, two spacer plates, two removable front braces, and a hardware pack.

The main receiver braces mount to the rear support plates, frame rails and the bumper core. The removable front braces install in the main receiver brace.

Before starting the installation, lay out the kit components in order, as they will be used. This will give you a visual idea of how the components work, and will also confirm that everything is present and accounted for.

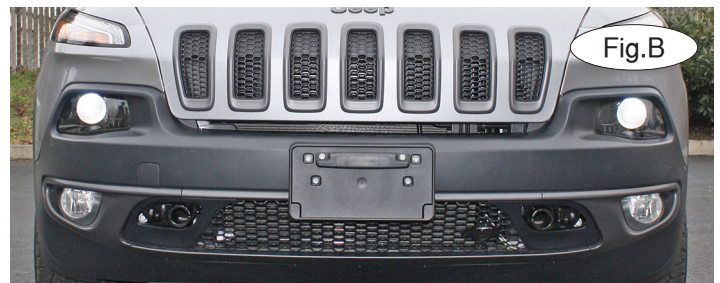

IMPORTANT: All baseplates **must** be assembled with all the bolts left loose for final adjustment and positioning (before tightening) unless otherwise instructed. All bolts **must** be torqued for proper strength. If more than one bolt is used per fastening point, the diagram may only show one. Use flat washers over all slotted holes and lock washers on all fasteners.

WARNING

Failure to heed these warnings or follow the installation instructions may result in a voided warranty, loss of towed vehicle, personal injury or death.

- Do not weld or modify this baseplate or its components. Welding or modification will void the warranty.
- Do not use this document as a basis to design/fabricate a baseplate, as it may not show all parts or structural components.
- We strongly recommend professional installation.
- If the towed vehicle has been in an accident, it must be properly repaired before attaching the baseplate. Do not install the baseplate if any structural frame damage is found.
- The installer must use all bolts and parts supplied. If running changes were made by the vehicle manufacturer after this kit was designed, some bolts or other fasteners may no longer be the correct size. It is the installer's responsibility to verify this kit is securely fastened to the vehicle.
- Use Loctite® Red on all bolts used to secure this baseplate. Torque all bolts to the specifications found at the end of these instructions. Do not over-torque the bolts or failure may occur.
- The installer must inspect the baseplate to ensure adequate clearance, particularly around hoses, air conditioner lines, radiators, etc. or non-warranty failure may result.
- Roadmaster manufactures many styles of baseplates. If your baseplate has removable arms, they must be removed before driving the vehicle, unless the arms can be pinned or padlocked in place. If not secured, the arms could vibrate out.
- Some motorhome chassis have such a tight turning radius that you can damage your motorhome, towed vehicle, tow bar or baseplate while turning sharply. Before getting on the road, test your turning radius in an empty parking lot. Turning too sharply could result in non-warranty damage to your towing system, motorhome and/or towed vehicle.
- Do not back up with the towed vehicle attached or non-warranty damage will occur to your towing system or vehicles.
- The safety cables must connect the towing vehicle to the towed vehicle frame to frame, with the cables crossed, with enough slack for sharp turns. See cable instructions for proper routing. Failure to do so will result in non-warranty damage and/or the loss of the towed vehicle.
- This kit is designed for use with ROADMASTER tow bars and ROADMASTER adapters only. Using this kit with other brands, without an approved ROADMASTER adapter, may result in non-warranty damage or injury.
- Receiver extensions and out-of-level towing situations of 3 inches or more. This can cause the system to swing much higher and lower, causing excessive strain on the tow bar, baseplate and frame. That can cause the towing system to fail, causing property damage, personal injury or even death. If you must use a receiver extension or drop hitch to tow, it will reduce your receiver's weight capacity by 1/3 to avoid damaging your system. Never use more than one extension and/or drop hitch, as this will void your warranty.
- Every 3,000 miles, the owner must inspect all mounting points for cracks or fatigue, and check the fasteners for proper torque, according to the bolt torque requirements chart on the last page of these instructions.
- The owner must follow the vehicle manufacturer's instructions to prepare the vehicle for towing. Failure to do so may cause severe damage to the vehicle.
- This baseplate is only warranted for the original installation. Installing a used baseplate on another vehicle is not recommended and will void the warranty.



BASEPLATE KIT INSTALLATION INSTRUCTIONS

KIT# 521446-5

05/23/23
KS

ROADMASTER, Inc. 6110 NE 127th Ave. Vancouver, WA 98682 360-896-0407 fax 360-735-9300 www.roadmasterinc.com

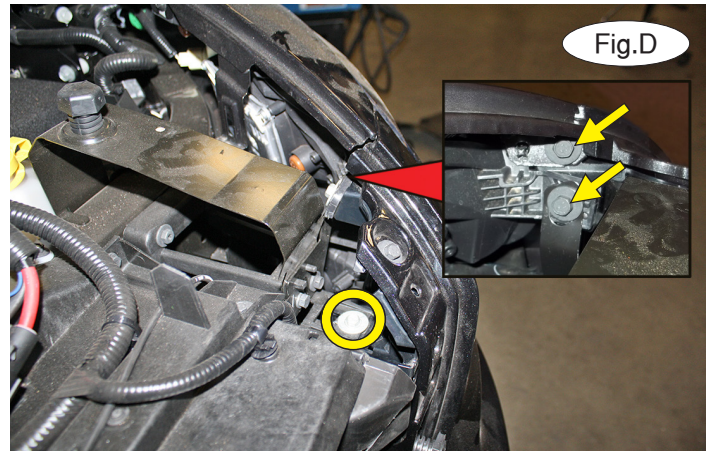
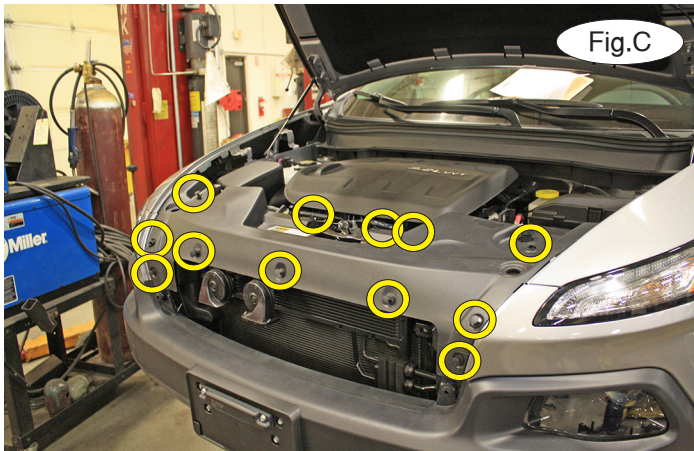

1. **Important:** please use all supplied bolts and parts and read all instructions carefully before beginning this installation. The majority of questions you may have can be answered within the text, and proper installation will ensure safe and secure travel. Now, begin the installation by removing 12 plastic fasteners attaching the radiator cover to the core support (Fig.C).

2. On each side, remove three 10mm (head) bolts attaching the fascia to the core support (Fig.D).

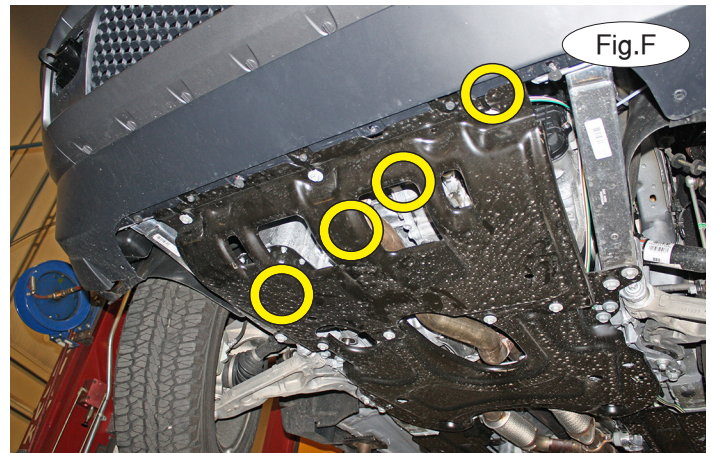

3. On each side, remove three 8mm (head) screws attaching the fender liner to the fascia (Fig.E).

4. Remove four 10mm (head) bolts attaching the fascia to the core support (Fig.F). *Note:* you may need to remove the skid plate first (next step).

5. Remove seven 13mm (head) bolts attaching the skid plate to the core support (Fig.G).

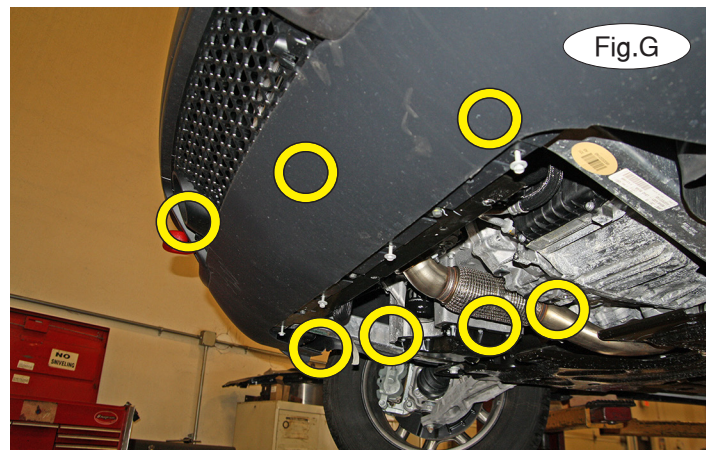



BASEPLATE KIT INSTALLATION INSTRUCTIONS

KIT# 521446-5

05/23/23
KS

ROADMASTER, Inc. 6110 NE 127th Ave. Vancouver, WA 98682 360-896-0407 fax 360-735-9300 www.roadmasterinc.com



6. On each side, use a 1/4" drill bit to remove the plastic pop rivet attaching the bottom of the fascia to the fender liner (Fig.H).
7. On each side, pull back the fender liner and remove one 10mm (head) bolt attaching the fascia to the fender (Fig.I).

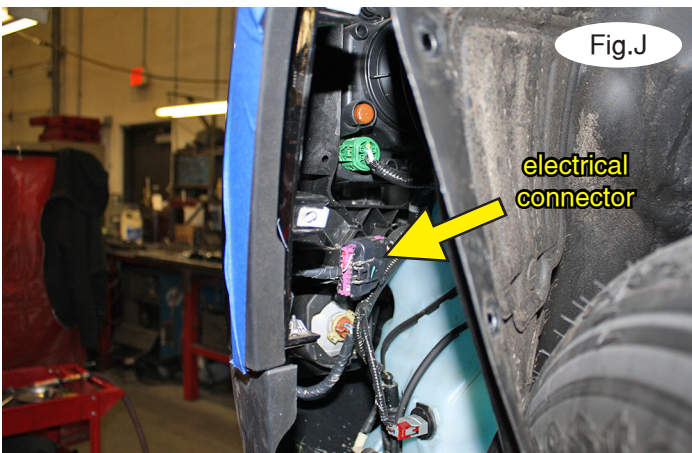

8. On the driver's side only, disconnect the purple electrical connector and a plastic fastener attaching the wiring loom to the core support (Fig.J). **Note: make certain that the vehicle is not turned on while this connector is unplugged or it may trigger the 'Check Engine' light to illuminate.**

9. On each side, pull out and forward on the corners of the fascia to remove it (Fig.K).

10. On each side, remove a 10mm nut and three 15mm (head) bolts attaching the aluminum brackets to the subframe (Fig.L). The brackets will not be replaced. **Note:** retain the brackets in case the main receiver brace is ever removed from the vehicle.



Caution! Under no circumstances should you attempt to move, adjust or disconnect the ACC unit, if the vehicle is so equipped. Doing so may cause cruise control malfunction and/or computer error codes that may require the dealership to repair or reset.



BASEPLATE KIT INSTALLATION INSTRUCTIONS

KIT# 521446-5

05/23/23
KS

ROADMASTER, Inc. 6110 NE 127th Ave. Vancouver, WA 98682 360-896-0407 fax 360-735-9300 www.roadmasterinc.com

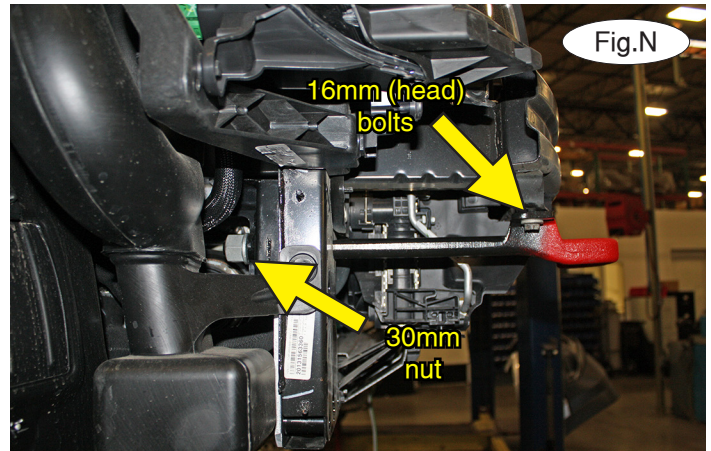
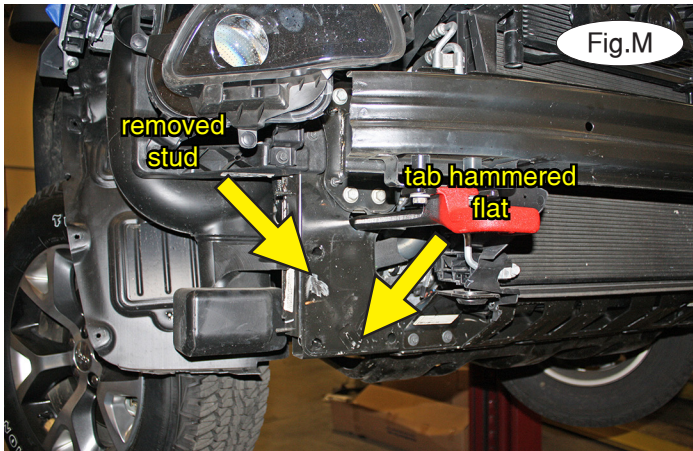

11. On each side, use a cut-off wheel to remove the exposed stud and use a hammer to flatten the alignment tab (Fig.M).
12. On each side, remove two 16mm (head) bolts attaching the tow hooks to the bottom of the bumper core. Now, use a crescent wrench on the 30mm nut attaching the tow hook to the rear of the tow hook bracket and then twist the front of the tow hook back and forth by hand to aid in removing the nut (Fig.N).

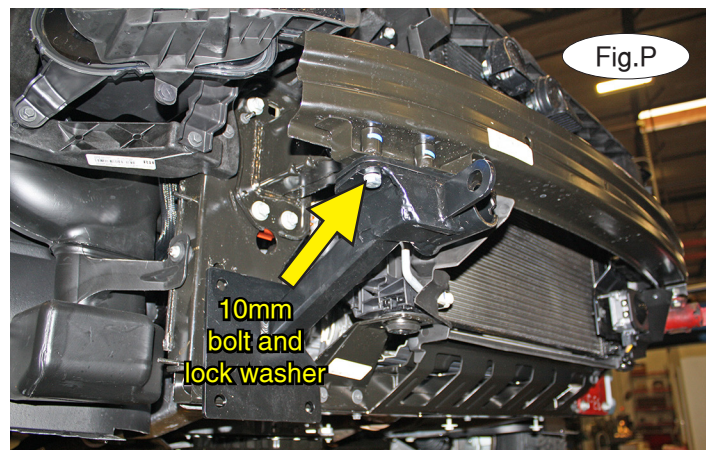
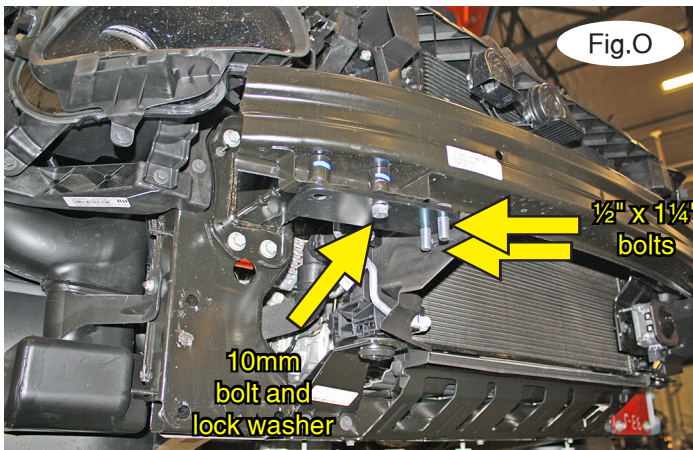

13. On each side, place the spacer plate on the under side of the bumper core and bolt up through the center mounting point using the supplied 10mm x 1.5 x 65mm bolt, 10mm lock washer and 3/8" flat washer. Now, place the 1/2" x 1 1/4" bolts down through the inside holes of the plate (Fig.O). Align the outside hole of the spacer plate with the other tow hook mount and then tighten the bolt.
Note: ensure proper alignment, as the bolts will receive Loctite® Red and will be torqued at the end of these instructions.

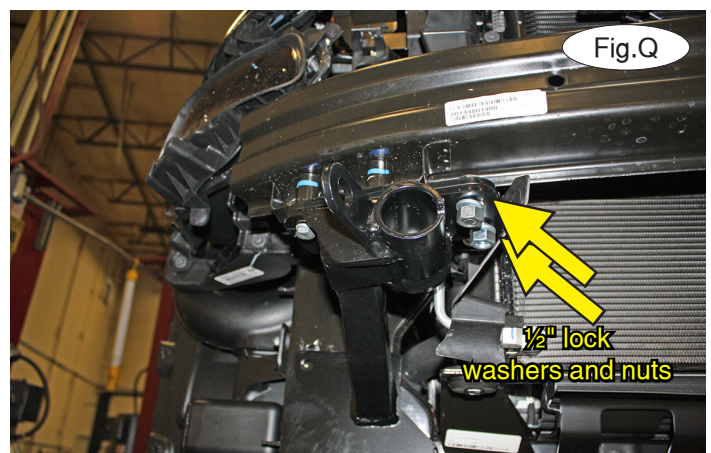

14. Align the main receiver brace with the holes in the spacer plate and ensure that the mounting surface of the bracket and the spacer plate are flush, and then use the supplied 10mm x 1.5 x 65mm bolt, 10mm lock washer 3/8" flat washer to bolt up through the main receiver brace and the spacer plate and into the tow hook mount (Fig.P).
15. On each side, finish the two 1/2" x 1 1/4" bolts on the inside holes of the spacer plate and main receiver brace by adding two 1/2" lock washers and nuts (Fig.Q).



BASEPLATE KIT INSTALLATION INSTRUCTIONS

KIT# 521446-5

05/23/23
KS

ROADMASTER, Inc. 6110 NE 127th Ave. Vancouver, WA 98682 360-896-0407 fax 360-735-9300 www.roadmasterinc.com

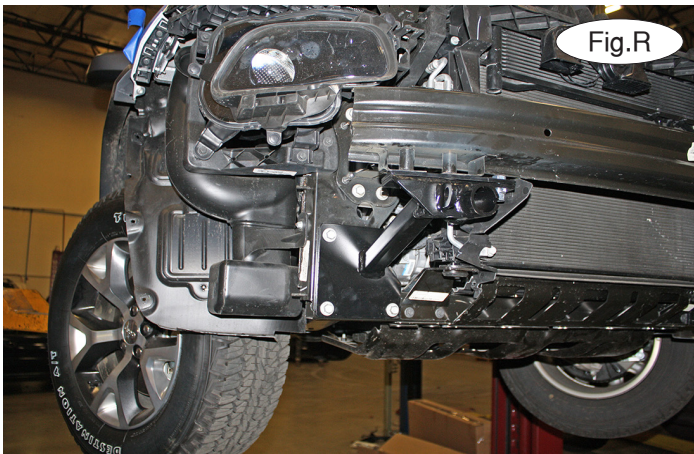

16. On each side, replace the three 15mm (head) bolts you removed in step 10 (Fig.R).

17. On each side, trim the front of the fascia as shown in Figure S and the back of the fascia as shown in Figure T using the yellow lines as references for trimming.

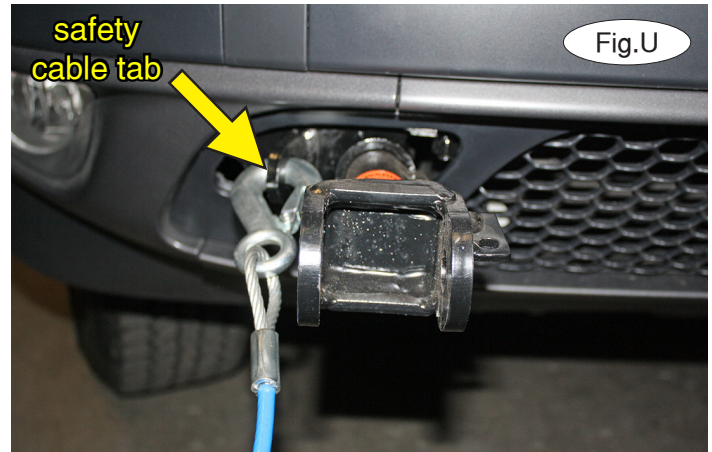

18. Now, torque all the bolts to the bolt torque requirements found at the end of these instructions. **Note: Use Loctite® Red on the bolts. Otherwise, it will loosen and result in failure of the towing system.**

19. Reinstall the fascia, reversing steps 1-9. *Note: use a pop rivet gun and the supplied pop rivets for reversing step 6.*

20. On each side, insert the removable front baseplate arm into the front receiver 90 degrees from its final towing position, depressing the spring-loaded pin against the receiver. Now, twist back 90 degrees until the spring-loaded pin snaps into place in the notch on the receiver, locking the arm into place in its final towing position.

Please note: it is the owner's responsibility to ensure the locking of the pins before towing. Otherwise, failure of the towing system will result.

21. Install the tow bar to the mounting bracket according to the manufacturer's instructions.

IMPORTANT!

Safety cables are required by law. When towing, connect safety cables to the safety cable tab shown in Figure U. Make certain there is adequate slack in the cables to allow a full turning radius; otherwise, damage will result. If necessary, longer cables or cable extensions are available.



BASEPLATE KIT INSTALLATION INSTRUCTIONS

KIT# 521446-5

05/23/23
KS

ROADMASTER, Inc. 6110 NE 127th Ave. Vancouver, WA 98682 360-896-0407 fax 360-735-9300 www.roadmasterinc.com

BOLT TORQUE REQUIREMENTS

Note: The torque values represented below are intended as general guidelines. Torque requirements for specific applications may vary. Roadmaster does not warrant this information to be accurate for all applications and disclaims all liability for any claims or damages which may result from its use.

STANDARD BOLTS

Thread Size	Grade	Torque
5/16-18	5	13 ft./lb.
3/8-16	5	23 ft./lb.
7/16-14	5	37 ft./lb.
1/2-13	5	57 ft./lb.
5/8-11	5	112 ft./lb.

METRIC BOLTS

Thread Size	Grade	Torque
6mm-1.0	8.8	6 ft./lb.
8mm-1.0	8.8	18 ft./lb.
8mm-1.25	8.8	16 ft./lb.
10mm-1.25	8.8	36 ft./lb.
10mm-1.5	8.8	31 ft./lb.

METRIC BOLTS

Thread Size	Grade	Torque
12mm-1.25	8.8	64 ft./lb.
12mm-1.5	8.8	60 ft./lb.
12mm-1.75	8.8	55 ft./lb.
14mm-2.0	8.8	88 ft./lb.

All illustrations and specifications contained herein are based on the latest information available at the time of publication approval. ROADMASTER, INC. reserves the right to make changes at any time without notice in material, specification and models or to discontinue models.